



# Super-precision angular contact thrust ball bearings for screw drives





The SKF brand now stands for more than ever before, and means more to you as a valued customer.

While SKF maintains its leadership as a high-quality bearing manufacturer throughout the world, new dimensions in technical advances, product support and services have evolved SKF into a truly solutions-oriented supplier, creating greater value for customers.

These solutions enable customers to improve productivity, not only with breakthrough application-specific products, but also through leading-edge design simulation tools and consultancy services, plant asset efficiency maintenance programmes, and the industry's most advanced supply management techniques.

The SKF brand still stands for the very best in rolling bearings, but it now stands for much more.

**SKF – the knowledge engineering company**

# Contents

## A Product information

**SKF super-precision angular contact thrust ball bearings for screw drives** . . . . . 3

**The most comprehensive assortment** 4  
Single direction angular contact thrust ball bearings. . . . . 4  
Double direction angular contact thrust ball bearings. . . . . 4  
Cartridge units with a flanged housing 5  
Tailored design . . . . . 5

**The new design: visible and invisible features make the difference** . . . . . 6  
Optimized internal design. . . . . 8  
Raceway/shoulder transition. . . . . 8  
Tightened tolerances . . . . . 8  
Low-friction seals. . . . . 9  
Unique heat treatment. . . . . 9

**For many industries: various benefits** 10

## B Recommendations

**Bearing selection** . . . . . 12  
Axial stiffness . . . . . 12  
Selecting single direction bearings according to stiffness requirements . . 14  
Selecting bearings according to speed capability . . . . . 18  
Attainable speeds . . . . . 18

**Bearing arrangement design** . . . . . 19  
Bearing sets . . . . . 19  
Accommodating misalignment. . . . . 20  
Bearings for the non-locating position 20  
Associated components . . . . . 20  
Application examples . . . . . 22

**Lubrication** . . . . . 23  
Greasing open bearings . . . . . 23  
Relubrication . . . . . 24  
Running-in of grease lubricated bearings . . . . . 24

## C Product data

**Single direction angular contact thrust ball bearings** . . . . . 26  
Matched bearing sets . . . . . 26  
Sealed bearings . . . . . 26  
Greased bearings . . . . . 26

**Double direction angular contact thrust ball bearings** . . . . . 27

**Double direction angular contact thrust ball bearings for bolt mounting** 28

**Cartridge units with a flanged housing** 29

**Bearing data – general** . . . . . 30  
Dimensions . . . . . 30  
Tolerances . . . . . 30  
Preload in unmounted bearings . . . . 30  
Frictional moment . . . . . 31  
Lifting force . . . . . 31  
Axial load carrying ability . . . . . 32  
Cages . . . . . 32  
Load ratings for bearing sets . . . . . 33  
Equivalent dynamic bearing load . . . . 33  
Equivalent static bearing load. . . . . 33  
Markings on bearings. . . . . 34  
Packaging. . . . . 35  
Designations . . . . . 35  
Designation system – table. . . . . 36

**Product tables** . . . . . 38  
C.1 . . . Single direction angular contact thrust ball bearings . . . . . 38  
C.2 . . . Double direction angular contact thrust ball bearings . . . . . 40  
C.3 . . . Double direction angular contact thrust ball bearings for bolt mounting 42  
C.4 . . . Cartridge units with a flanged housing . . . . . 44

## D Additional information

**SKF – the knowledge engineering company** . . . . . 46

# SKF super-precision angular contact thrust ball bearings for screw drives

Machine tools require screw drives that can position a work piece or machine component quickly, efficiently and precisely. To meet these requirements, screw drives are usually supported at both ends by super-precision bearings that can provide a high degree of stiffness. The bearings may also have to accommodate high acceleration and high speed. SKF has developed super-precision angular contact ball bearings that can meet these ever-increasing performance requirements.

The characteristic properties of these angular contact thrust ball bearings include:

- high axial stiffness
- high axial load carrying capacity
- very high running accuracy
- low frictional moment
- ability to accommodate high speeds and accelerations

SKF angular contact thrust ball bearings for screw drives are especially suitable for screw drive applications, but are also beneficial in other applications, where safe radial and axial support is required, together with extremely precise axial guidance of the shaft. What makes these bearings so special is explained on the following pages.

## Comprehensive assortment

The SKF assortment can accommodate virtually any requirement placed on support bearings for screw drives. Single direction bearings enable a variety of bearing arrangements. Double direction bearings reduce the number of components. Cartridge units and bearings for bolt mounting are quick and easy to install. Sealed bearings provide more reliability in harsh environments. For additional details about the SKF offer, see the following pages.



# The most comprehensive assortment

The comprehensive SKF assortment provides the right support bearing for virtually every screw drive application. It is available from one single source. The assortment comprises:

- Single direction bearings for bearing arrangements adjusted to individual requirements and with enhanced performance resulting from the SKF design.
- Double direction bearings for easy and quick mounting in the proven SKF design.
- Cartridge units contain SKF single direction bearings and are ready-to-mount units.

## Single direction angular contact thrust ball bearings

Single direction bearings provide all the features necessary for high-performance screw drive supports, but are not limited to these applications. They are characterized by:

- superior axial stiffness
- low frictional moment
- designed to accommodate high speeds and rapid accelerations
- excellent running accuracy according to ISO tolerance class 2 (ABEC 9)
- dimensional accuracy according to ISO tolerance class 4 (ABEC 7)
- high axial load carrying capacity
- universally matchable in sets of up to four bearings
- unique heat treatment for constant preload over the entire service life of the bearing

The bearings are available open or with low-friction seals.

## Double direction angular contact thrust ball bearings

SKF double direction angular contact thrust ball bearings have been developed for machine tool applications where space is tight and easy mounting is required. They accommodate axial loads in both directions. Preload is applied by clamping the inner ring halves with a precision lock nut. These bearings are sealed and greased as standard. Bearings in the BEAM series can be bolt mounted to an associated component. Other features include:

- holes for relubrication via the outer ring
- either contact seals or non-contact shields

### Single direction angular contact thrust ball bearings

SKF series designation	BSA, BSD
SNFA series designation	BS
Bore diameter range	12 to 75 mm



Open

Sealed

### Double direction angular contact thrust ball bearings

Series designation	BEAS
Bore diameter range	8 to 30 mm



### Double direction angular contact thrust ball bearings for bolt mounting

Series designation	BEAM
Bore diameter range	12 to 60 mm



- manufactured according to ISO tolerance class 4 (ABEC7)

mation, contact the application engineering service.

## Cartridge units with a flanged housing

Cartridge units are another solution for easy and quick mounting. The units incorporate SKF single direction bearings and all their benefits. The main characteristics of cartridge units are:

- designed for high stiffness and heavy axial loads
- all bearing arrangements are possible (back-to-back, face-to-face, tandem and other combinations)
- sealed with laminar rings
- grease service life is intended to outlast the bearing

## Tailored design

The standard SKF assortment covers a wide variety of application conditions. But it can also be considered as the basis to develop specialized solutions. For additional infor-

## Greased bearings

Sealed SKF bearings and units are supplied greased, as standard. Open, single direction bearings can also be supplied greased on demand. Customers can choose a suitable SKF grease or specify the grease type and quantity to meet the needs of their application. With this service, accuracy in terms of quantity, grease distribution and cleanliness are maintained by the factory.

## Customized solutions

Advanced modelling and virtual testing services enable the application engineering service to assist in all stages of product development. With core competencies in bearings, seals, lubrication, mechatronics and services, the SKF team can help to design customized solutions that meet the requirements of the next generation of machine tools.

### Cartridge units with a flanged housing

SKF series designation	FBSA
SNFA series designation	BSDU, BSQU
Bore diameter range	20 to 60 mm





# Premium performance: visible and invisible features make the difference

When designing bearings, competing requirements have to be considered. The most important requirements for support bearings for screw drives are a high degree of stiffness and a low frictional moment. However, other important requirements include adequate axial load carrying capacity, a high degree of running accuracy as well as high speed capability and the ability to accommodate rapid accelerations and deceleration.

During the integration of SNFA into SKF in 2008, SKF engineers used their vast expertise in this area to design an upgraded assortment of super-precision single direction angular contact thrust ball bearings for

screw drives. Following are some of the features of these optimized bearings:

- a fine-tuned osculation
- a 62° contact angle
- a ground transition between each raceway and its shoulder
- a robust cage
- a unique heat treatment
- very clean bearing steel
- tightened manufacturing tolerances
- universally matchable – sets of up to four bearings can be combined
- sealed versions available

The outcome is measurable, especially for the most important factors of stiffness and friction (→ **diagrams 1 to 4**).

*The benefits of SKF bearings are partly visible, partly hidden in the components*



Diagram 1

**Stiffness comparison**

Spring curve for two bearings BSA 202 GCA (*BS 215 7P62 DUM*<sup>1)</sup>) arranged face-to-face

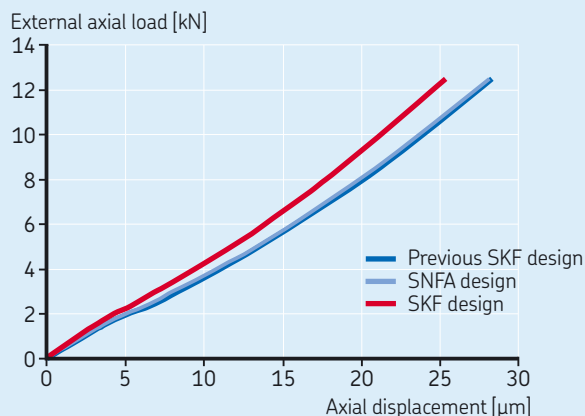

<sup>1)</sup> Where applicable, designations in parentheses and italics refer to the corresponding SNFA equivalent.

Diagram 2

**Stiffness comparison**

Spring curve for two bearings BSA 207 GCA (*BS 235 7P62 DUM*) arranged face-to-face

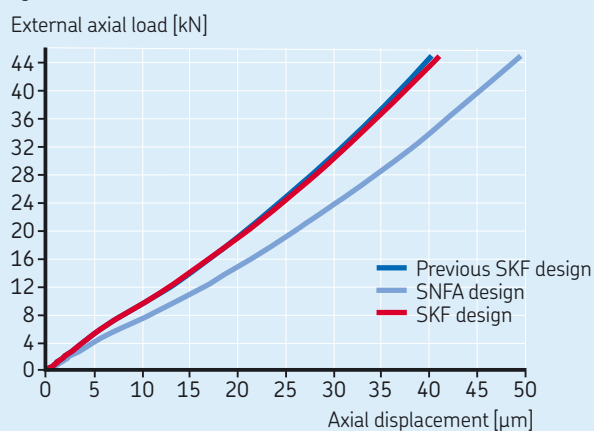

Diagram 3

**Stiffness comparison**

Spring curve for two bearings BSA 210 CGA (*BS 250 7P62 DUM*) arranged face-to-face

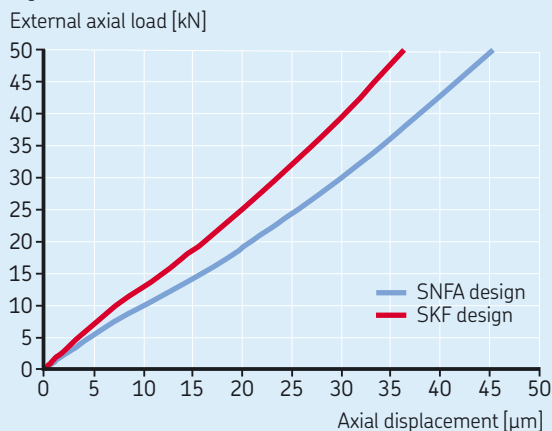
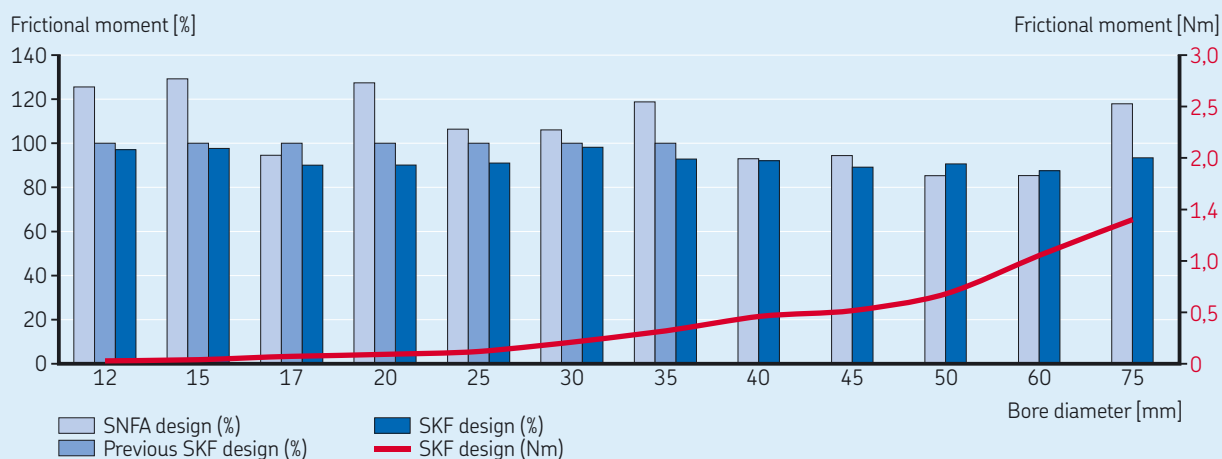

Diagram 4

**Friction comparison**

Bearing series BSA 2 (*BS 2*), preload class B



## Optimized internal design

SKF single direction angular contact thrust ball bearings have been optimized in terms of stiffness and friction. High stiffness values and low friction levels were achieved by fine-tuning the osculation, increasing the contact angle to  $62^\circ$  and modifying the tolerance range of the contact angle. Other improvements include the transition between the raceway and shoulder to increase the axial load carrying capability and cage improvements to extend speed capability.

## Raceway/shoulder transition

Changing demands in machine tool applications require bearings that can accommodate heavy axial loads. These loads can change the contact conditions in a bearing. When an axial load is present, the pressure-ellipses in the ball-raceway contact areas become larger and the point of contact between a ball and raceway moves closer to the shoulder. Under these conditions, edge stresses may occur in conventional bearings, which can have a detrimental effect on bearing service life.

SKF single direction bearings have a ground transition radius between the raceway and shoulder. This radius reduces edge stresses by approximately 30 %, which enables these bearings to accommodate incidental overloading better than conventional designs.

*Transition between the raceway and shoulder*

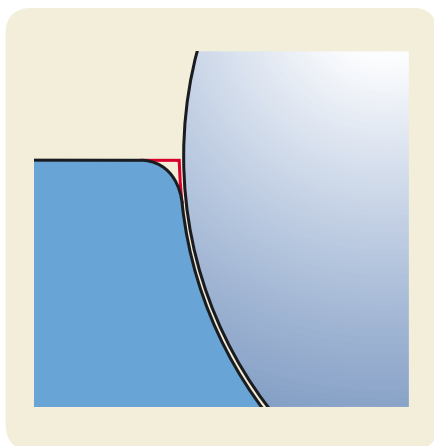

## Tightened tolerances

SKF single direction bearings are manufactured to tight tolerances, especially for the bore, outside diameter and stand-out. With these improvements, sets made of universally matchable bearings have reached the performance level of matched sets.

Inventory reduction is an additional benefit resulting from these tighter tolerances. Virtually any set of up to four bearings can be arranged using universally matchable bearings, eliminating the need to order and inventory different matched sets. All SKF single direction angular contact ball bearings are universally matchable.

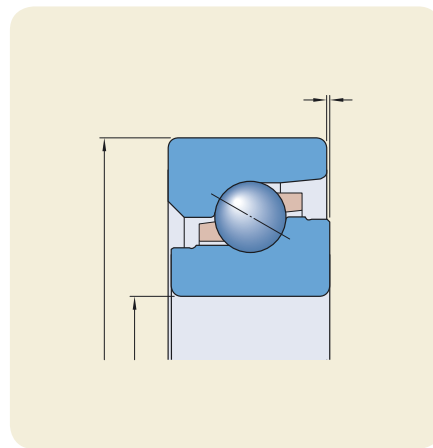

*Tightened tolerances for the bore, outside diameter and stand-out*

*Typical stresses in the contact area in a bearing subjected to heavy axial load*

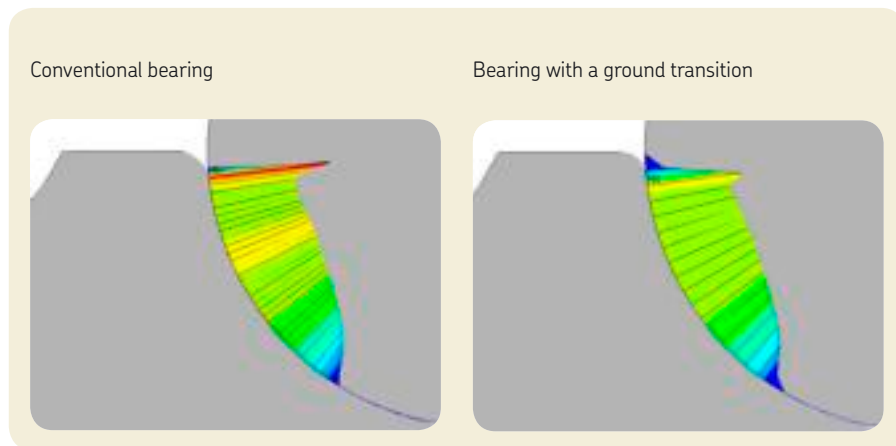



## Low-friction seals

When comparing a sealed bearing to an open bearing and external seals, a sealed bearing provides the following benefits:

- fewer components
- reduced assembly time
- no risk of over or under greasing the bearing
- reduced risk of grease contamination
- less need for maintenance
- extended service life

Because of their versatility, sealed bearings are becoming more and more common in screw drive applications. SKF sealed bearings, which use low-friction seals, have virtually eliminated the need to order bearings or bearing sets with a special seal configuration on one side or the other.

The seal forms an extremely narrow gap with the shoulder or recess profile of the inner ring and is practically non-contacting. Because of this, these bearings do not generate any more friction than a seal on only one side of the bearing, enabling them to operate at the same high speeds as bearings without seals. SKF single direction angular contact thrust ball bearings are available with low-friction seals.

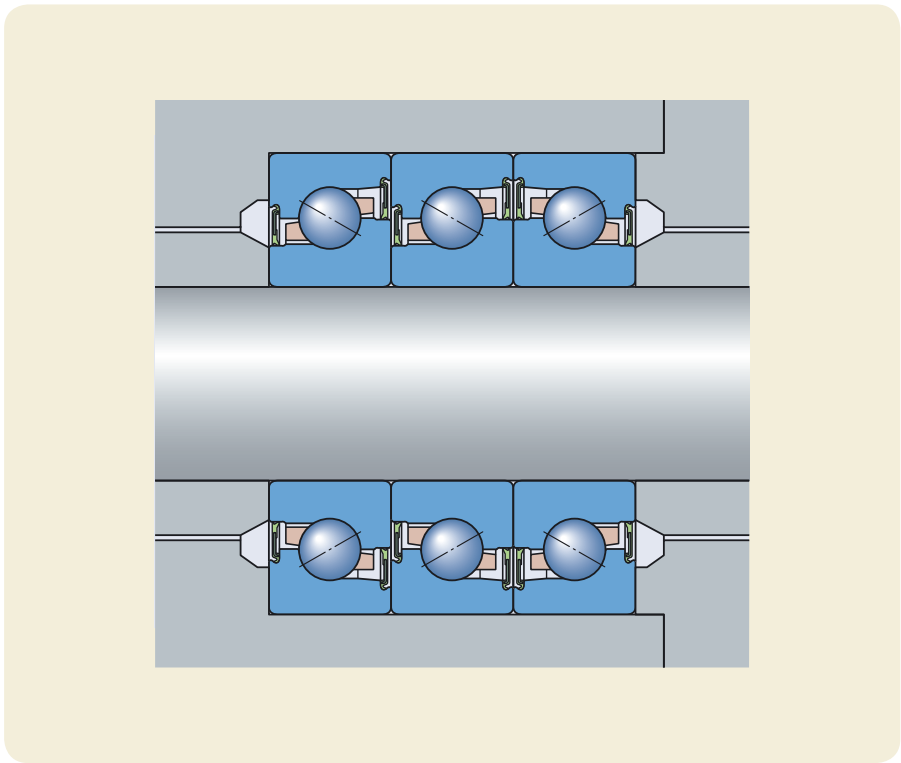

*SKF sealed single direction bearings can replace open bearings and bearings with a special seal configuration*

## Unique heat treatment

SKF single direction angular contact thrust ball bearings undergo a unique heat treatment. This heat treatment process is similar to that applied to SKF Explorer bearings. It optimizes the balance between hardness and dimensional stability. Hardness is essential for low friction and long service life. Dimensional stability is a key factor in maintaining proper preload, which has a direct impact on the service life of the bearing and the stiffness of a bearing arrangement. SKF single direction bearings are stabilized for temperatures up to 150 °C. Screw drives operate typically at much lower temperatures. This means that dimensional changes during operation are negligible.

### SKF super-precision bearings in the BSA/BSD (BS) series

#### Features

- fine-tuned osculation
- 62° contact angle
- ground transition between raceways and shoulder
- unique heat treatment
- stabilized for temperatures up to 150 °C
- robust cage design
- universally matchable in sets with up to four bearings
- low-friction seals available

#### Benefits

- optimized in terms of stiffness and friction
- high axial load carrying capacity
- less sensitive to incidental overloading
- constant preload over the entire service life
- suitable for high speeds
- no need for matched sets

# For many industries: various benefits

SKF super-precision angular contact thrust ball bearings can provide a variety of benefits to applications in and outside the machine tool industry.

In machine tools, these bearings, which can accommodate very fast starts and stops, and high speeds, enable quick movements and precise positioning; prerequisites for high quality products and high output levels. In printing applications, these bearings contribute to high-quality output and increased machine uptime. They can fulfil the unique requirements of the aerospace industry for reliability and traceability.

The wide assortment provides solutions for virtually all application requirements. It covers universally matchable bearings to be arranged in different sets as well as ready-to-mount units for quick assembly or fast replacement. Via the SKF logistics system, the bearings are available worldwide with short delivery times.

## Industries

- Machine tool
- Aerospace
- Printing
- Material handling
- Injection moulding

## Requirements

- High positioning accuracy
- Reliable positioning repeatability
- Safe operation under rapid accelerations and high speeds
- Suitable for heavy axial loads
- Low energy consumption
- Long service life without maintenance
- Easy and quick mounting
- Increased machine uptime
- High power density for compact designs

## Solution





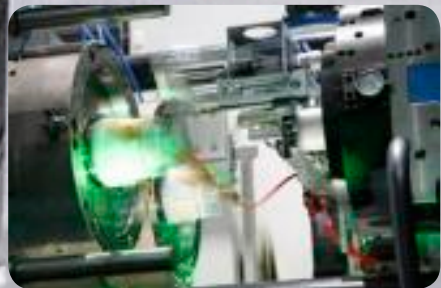
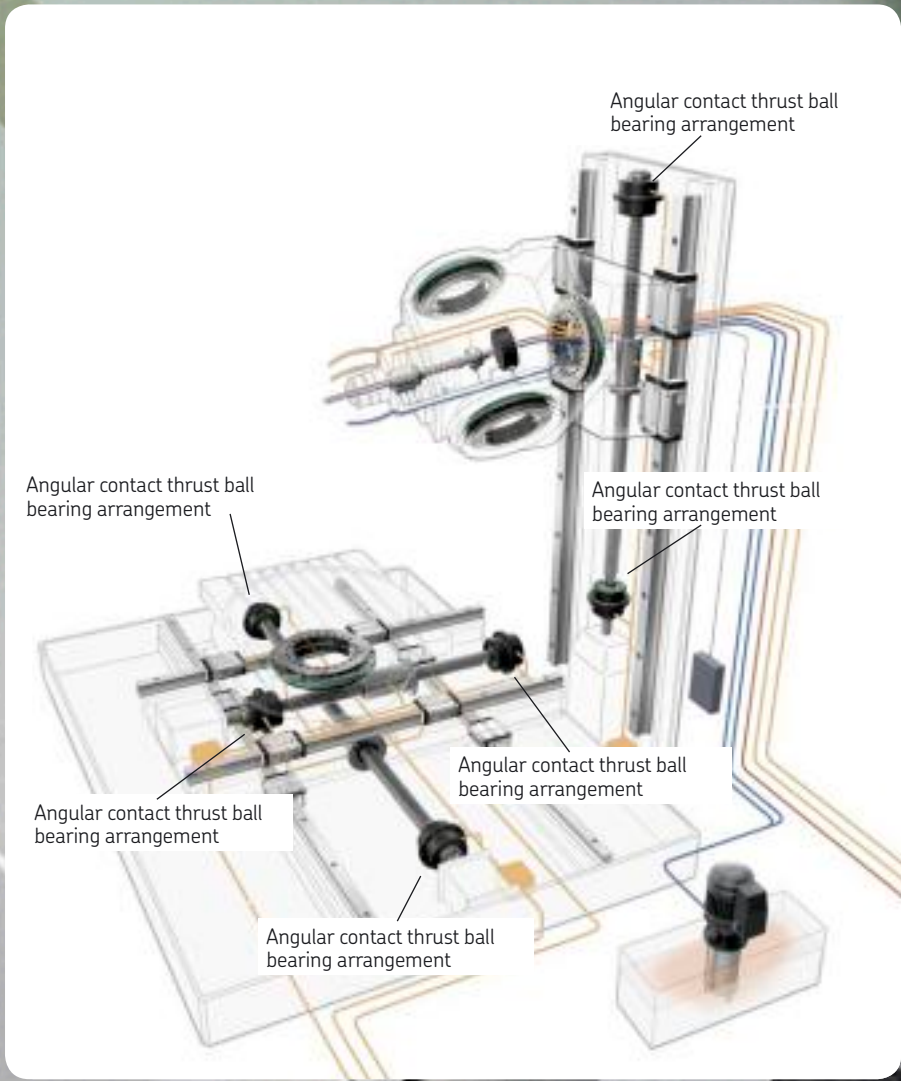

# Bearing selection

The main criteria used when selecting bearings to support screw drives are axial stiffness and load carrying capacity, running accuracy, speed and frictional moment. Other factors to consider can be the pivotal stiffness of a bearing arrangement or the ability to cope with misalignment between the shaft and housing. Additional criteria can include mounting or sealing requirements. **Table 1** provides an overview of the criteria and to what extent the different bearing series fulfil the requirements.

The table shows that there are no differences between the bearing series in terms of axial load carrying capacity, running accuracy, speed capability and frictional moment. However, when it comes to axial stiffness, special arrangements or mounting requirements, the different bearings series show different advantages.

## Axial stiffness

Axial stiffness is a main criterion when selecting bearings for screw drives. SKF super-precision angular contact thrust ball bearings provide a very high degree of axial stiffness.

## Single direction bearings

The nominal stiffness values for single direction bearings are listed in **table 2**. They apply to unmounted bearing sets with two bearings in a back-to-back or face-to-face arrangement.

Bearing sets comprising three or four bearings (→ **fig. 1, page 19**) can provide a higher degree of axial stiffness than sets with two bearings. The degree of stiffness

for these bearing sets can be calculated by multiplying the values listed in **table 2** by a factor of:

- 1,45 to 1,65 for sets with three bearings, arranged in tandem and back-to-back or face-to-face
- 1,8 to 2,25 for sets with four bearings, arranged in tandem and back-to-back or face-to-face
- 2 for sets with four bearings, arranged back-to-back or face-to-face

The lower value factor applies to bearings under light axial load ( $P \leq 0,05 C$ ) and the larger value to bearings under heavy axial load ( $P > 0,1 C$ ). For determining the equivalent dynamic bearing load  $P$ , refer to the section on **page 33**.

Table 1

### Selection criteria for angular contact ball bearings for screw drives

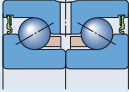
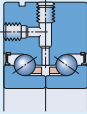
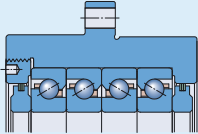
Bearing type	Single direction bearings	Double direction bearings	Double direction bearings for bolt mounting	Cartridge units
				
Series designation SKF	BSA, BSD	BEAS	BEAM	FBSA
Series designation SNFA	BS2, BS	BEAS	BEAM	BSDU, BSQU

### Selection criteria

Axial stiffness	++	+	+	++
Axial load carrying capacity	++	++	++	++
Running accuracy	++	++	++	++
Speed capability	++	+	+	+
Frictional moment	++	+	+	++
Flexibility in arrangement	+	o	o	++
Easy mounting	o	+	++	++
Seals	none or low-friction seals	shields or contact seals	shields or contact seals	laminar rings

Symbols: ++ very good + good o suitable

Bearing sets with a heavier preload provide an even higher degree of stiffness. However, this should be avoided as heavier preload substantially increases friction and heat, generated by the bearing. In cases where an extremely high degree of stiffness is required, contact the application engineering service. They have simulation tools to estimate the frictional behaviour when preload is increased.

## Cartridge units

For cartridge units, axial stiffness is listed in the product table (→ pages 44 and 45). The values correspond to those for the appropriate single bearing multiplied by the above factors according to the arrangement.

## Double direction bearings

The axial and pivotal stiffness of double direction angular contact thrust ball bearings in the BEAS and BEAM series are shown in **table 3** and apply to the preload set at the factory, without influence from fit or operation.

Table 2

### Axial stiffness of single direction angular contact thrust ball bearings

Designations SKF	SNFA	Axial stiffness <sup>1)</sup> Preload class	
		A	B
		N/μm	
BSA 201 C	BS 212	400	510
BSA 202 C	BS 215	460	580
BSA 203 C	BS 217	550	700
BSA 204 C	BS 220	680	860
BSA 205 C	BS 225	725	925
BSA 206 C	BS 230	870	1 110
BSA 207 C	BS 235	1 080	1 370
BSA 208 C	BS 240	1 130	1 440
BSA 209 C	BS 245	1 290	1 640
BSA 210 C	BS 250	1 410	1 800
BSA 212 C	BS 260	1 640	2 080
BSA 215 C	BS 275	1 870	2 380
BSA 305 C	BS 325	870	1 110
BSA 306 C	BS 330	1 010	1 280
BSA 307 C	BS 335	1 120	1 430
BSA 308 C	BS 340	1 340	1 710
BSD 2047 C	BS 20/47	680	860
BSD 2562 C	BS 25/62	870	1 110
BSD 3062 C	BS 30/62	870	1 110
BSD 3572 C	BS 35/72	1 080	1 370
BSD 4072 C	BS 40/72	1 080	1 370
BSD 4090 C	BS 40/90	1 340	1 710
BSD 4575 C	BS 45/75	1 180	1 500
BSD 45100 C	BS 45/100	1 470	1 870
BSD 50100 C	BS 50/100	1 550	1 970
BSD 55100 C	BS 55/100	1 550	1 970
BSD 55120 C	BS 55/120	1 800	2 300
BSD 60120 C	BS 60/120	1 800	2 300

<sup>1)</sup> The values are valid for unmounted bearing sets with two bearings arranged back-to-back or face-to-face.

Table 3

### Axial and pivotal stiffness of double direction angular contact thrust ball bearings

Designations SKF	SNFA	Axial stiffness <sup>1)</sup>	Pivotal stiffness <sup>1)</sup>
		N/μm	Nm/mrad
BEAS 008032	BEAS 8/32	250	20
BEAS 012042	BEAS 12/42	350	80
BEAS 015045	BEAS 15/45	400	65
BEAS 017047	BEAS 17/47	420	80
BEAS 020052	BEAS 20/52	650	150
BEAS 025057	BEAS 25/57	770	200
BEAS 030062	BEAS 30/62	870	300
BEAM 012055	BEAM 12/55	350	80
BEAM 017062	BEAM 17/62	420	80
BEAM 020068	BEAM 20/68	650	150
BEAM 025075	BEAM 25/75	770	200
BEAM 030080	BEAM 30/80	870	300
BEAM 030100	BEAM 30/100	950	470
BEAM 035090	BEAM 35/90	900	400
BEAM 040100	BEAM 40/100	1 000	570
BEAM 040115	BEAM 40/115	1 150	720
BEAM 050115	BEAM 50/115	1 250	1 000
BEAM 050140	BEAM 50/140	1 350	1 500
BEAM 060145	BEAM 60/145	1 400	1 750

<sup>1)</sup> The values are valid for unmounted bearings.

# Selecting single direction bearings according to stiffness requirements

Selecting single direction bearings according to stiffness requirements can be done with **diagrams 1 to 4** on **pages 14 to 17**. The diagrams provide spring curves for bearing sets with two bearings arranged back-to-back or face-to-face and enable bearing selection based on the axial load.

For a given axial load, the axial displacement can be found for different bearing sets. The axial displacement for bearing sets comprising more than two bearings can be calculated by dividing the axial displacement for a set of two bearings with the factor for the degree of stiffness mentioned above.

## Example: Determining the axial displacement for bearing sets with preload class A

For an axial load of 22 kN, the smallest possible bearing is a BSA 205 (BS 225). A set of two BSA 205 CGA (BS 225 7P62UM) bearings arranged back-to-back or face-to-face will be displaced under load by approximately 30  $\mu\text{m}$  ( $\rightarrow$  **diagram 1**). A set of two BSA 207 CGA (BS 235 7P62UM) bearings will be displaced by 22  $\mu\text{m}$ . A set of two BSA 215 CGA (BS 275 7P62UM) bearings provides the highest stiffness

Diagram 1

Spring curves for bearing sets with two bearings mounted back-to-back or face-to-face, bore diameter 12 to 35 mm, preload class A

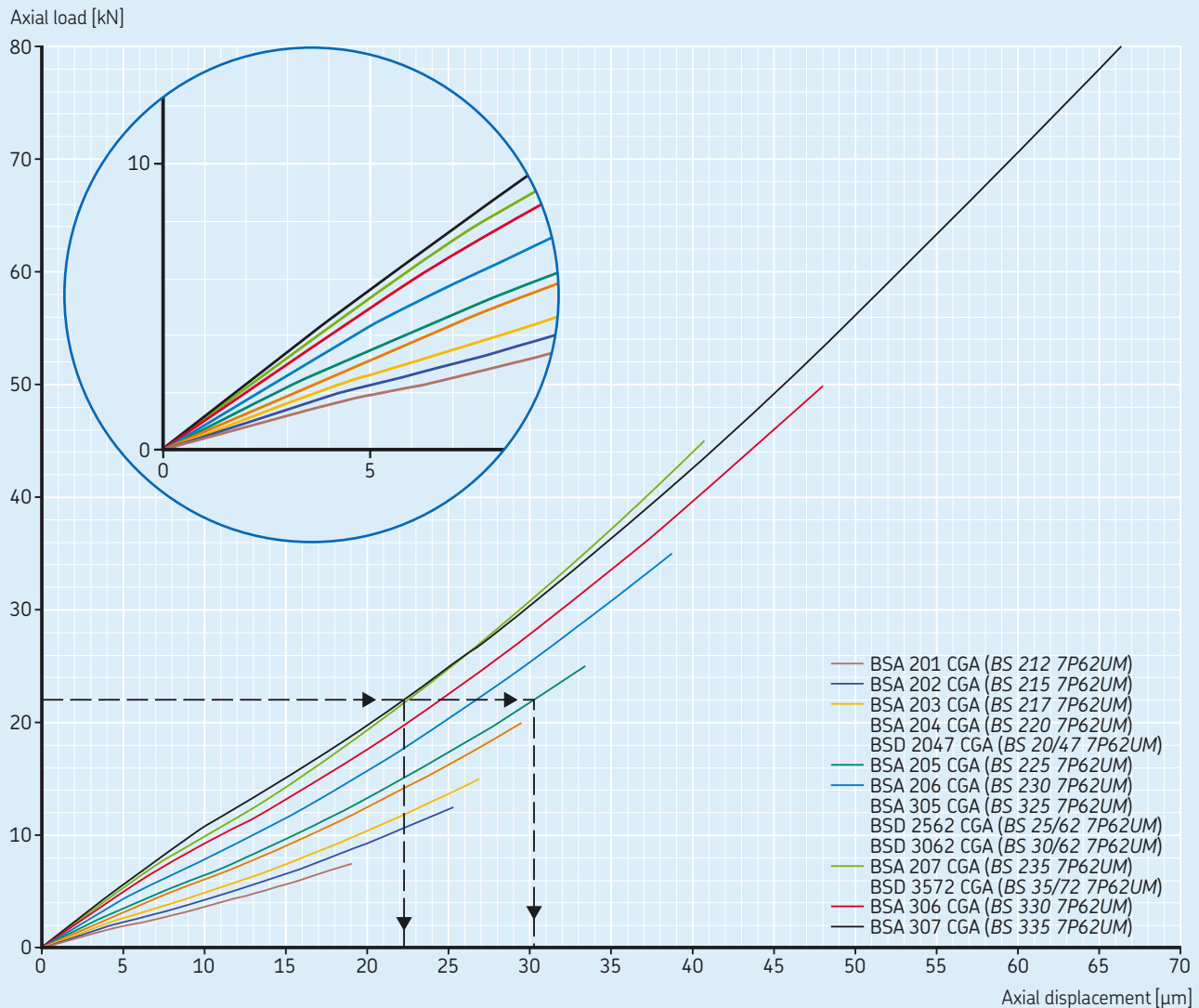



(→ diagram 2). They will have an axial displacement under load of only 13 µm.

Even higher stiffness is possible with a set of four bearings. The axial displacement for a cartridge unit FBSA 207/QBC (BSQU 235 TDT) is 22/2, means 11 µm.

Diagram 2

Spring curves for bearing sets with two bearings mounted back-to-back or face-to-face, bore diameter 40 to 75 mm, preload class A

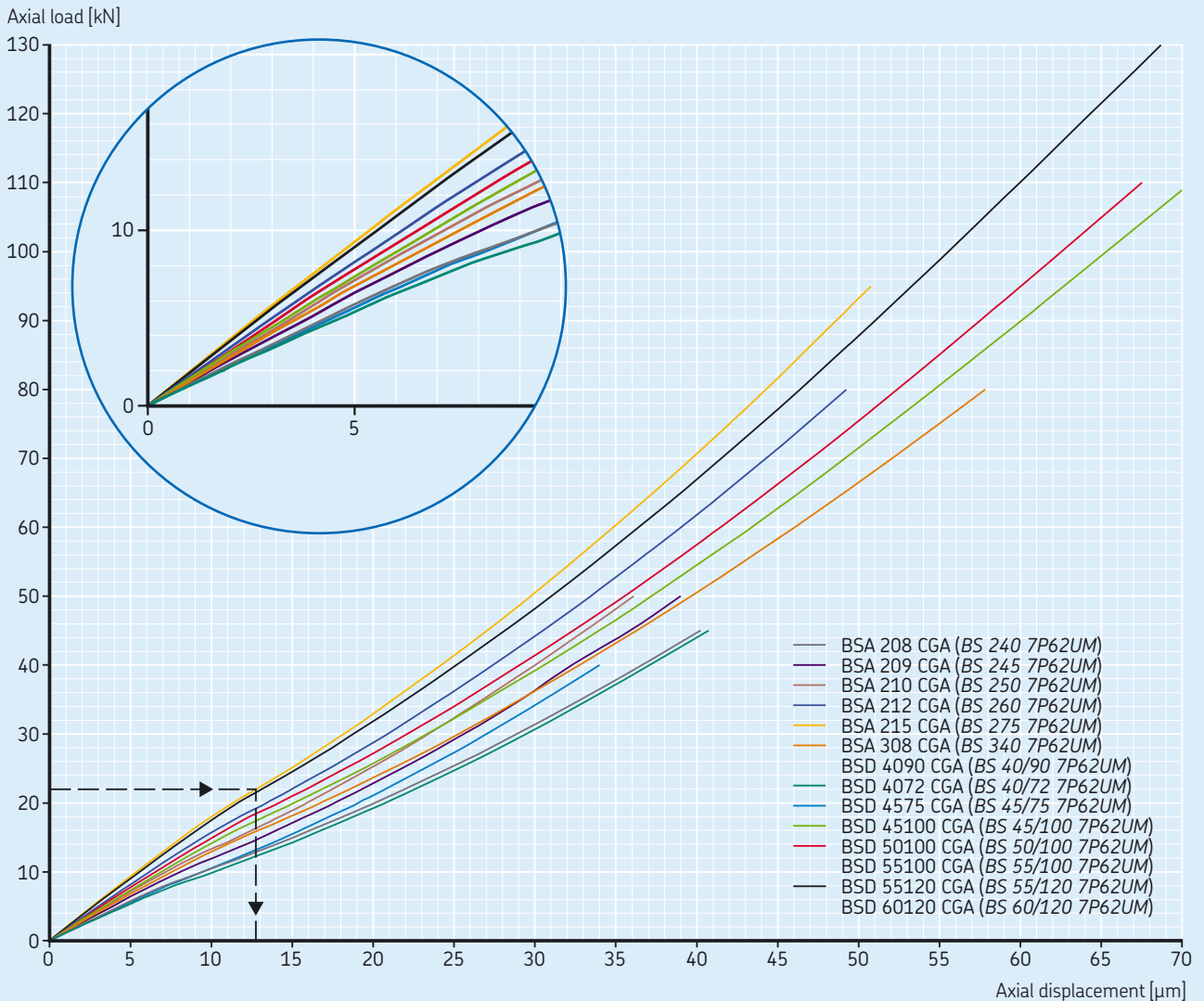

Spring curves for bearing sets with two bearings mounted back-to-back or face-to-face, bore diameter 12 to 35 mm, preload class B

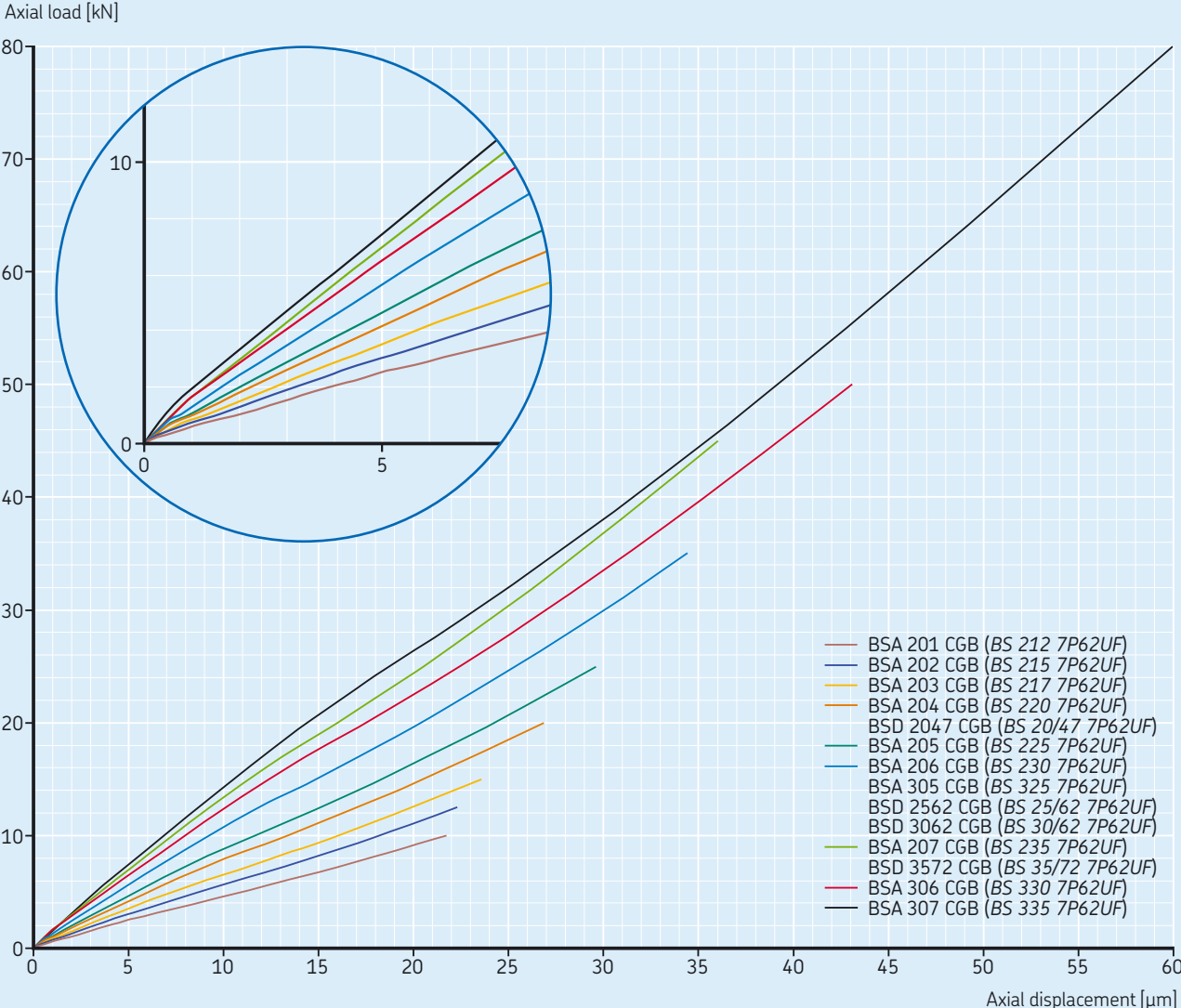
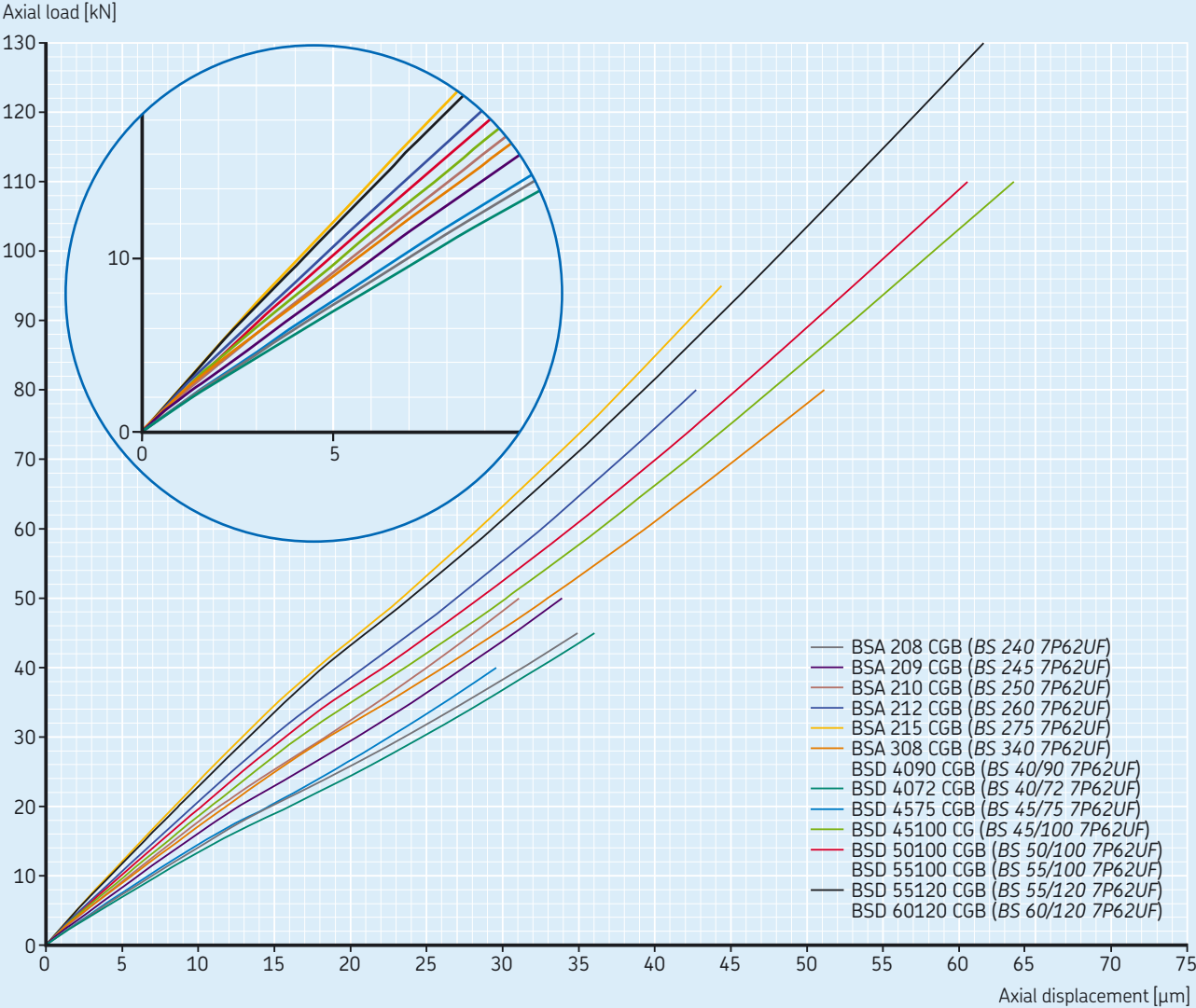

Diagram 4

Spring curves for bearing sets with two bearings mounted back-to-back or face-to-face, bore diameter 40 to 75 mm, preload class B



# Selecting bearings according to speed capability

The speed at which a super-precision angular contact thrust ball bearing can operate is largely determined by the temperature of the bearing during operation. **Diagram 5** provides guideline values for the speeds attainable by bearings in the different series. The diagram is based on the speed factor A, which is

$$A = n d_m$$

where

A = speed factor [mm/min]

n = rotational speed [r/min]

$d_m$  = bearing mean diameter [mm]  
 $= 0,5 (d + D)$

When designing screw drive bearing arrangements for high speeds (i.e. near to or beyond the attainable speed listed in the product tables), additional factors should be considered, such as:

- bearing preload
- bearing arrangement
- accuracy of associated components
- lubricant and lubrication method
- cooling
- critical speeds

For additional information, contact the application engineering service.

## Attainable speeds

The attainable speeds listed in the product tables are guideline values and apply to bearings under light load ( $P \leq 0,05 C$ ) and assume good heat dissipation from the bearing.

### Single direction bearings

The speed ratings for oil-air lubrication listed in the product table for single direction bearings (→ **pages 38 and 39**) must be reduced if other oil lubrication methods are used. The values provided for grease lubrication are maximum values that can be attained with a low viscosity, high quality grease. Speeds should also be reduced for a bearing set with two, three or four bearings used immediately adjacent to each other. In

Diagram 5

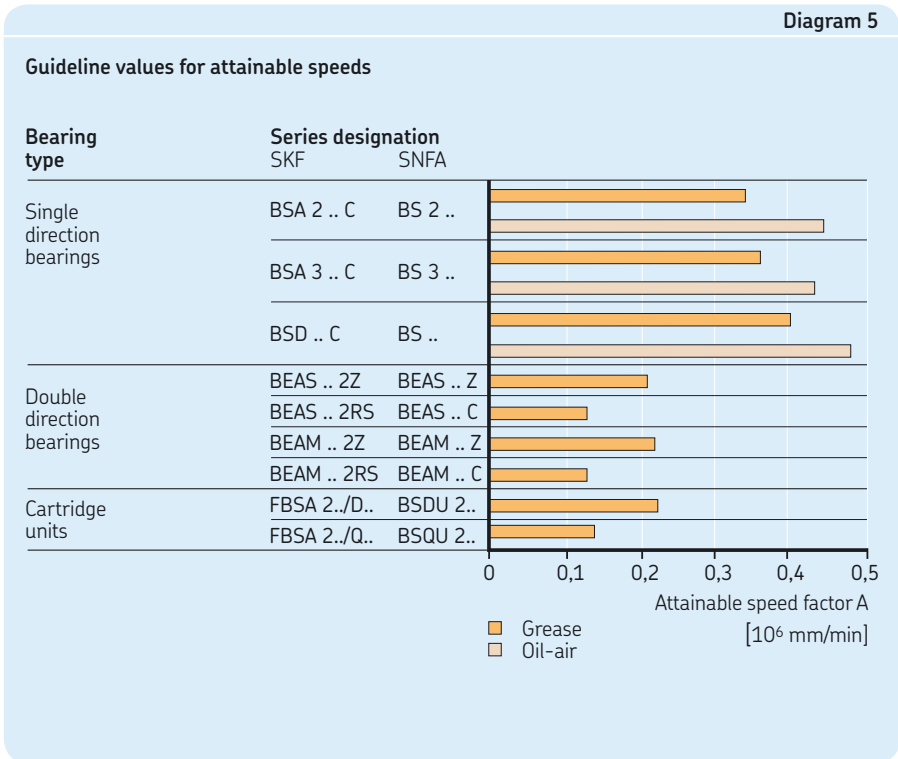

these cases, guideline values can be calculated by multiplying the values in the product table with the reduction factor that coincides with the preload and the number of bearings in an arrangement (→ **table 4**). If the speeds calculated are not adequate for the application, contact the application engineering service.

### Double direction bearings

The attainable speeds listed in the product table for double direction bearings (→ **pages 40 to 43**) depend on the type of seal. They are limited for bearings with seals (designation suffix 2RS or C) by the permissible sliding speed at the sealing lip, and for bearings with shields (designation suffix 2Z or Z), by the speeds permitted for grease lubrication.

#### Cartridge units with a flanged housing

The attainable speeds listed in the product tables for cartridge units (→ **pages 44 and 45**) apply to mounted, grease lubricated units.

Table 4

**Speed reduction factors for bearing sets with single direction bearings**

Number of bearings per set	Reduction factor for preload class	
	A	B
2	0,8	0,4
3	0,65	0,3
4	0,5	0,25

# Bearing arrangement design

## Bearing sets

Single direction angular contact thrust ball bearings for screw drives enable flexible bearing arrangement design. As standard, they are universally matchable for mounting as sets with up to four bearings per set. The bearings can be used for all combinations as per **fig. 1**.

Universally matchable bearings are specifically manufactured so that when mounted in random order, but immediately adjacent to each other, a given preload or an even load distribution is obtained without the use of shims or similar devices. They have very tight tolerances for the bore and outside diameter as well as for radial runout.

### Back-to-back bearing arrangements

In a back-to-back arrangement (→ **fig. 1**), the load lines diverge toward the bearing axis. Axial loads acting in both directions can be accommodated, but only by one bearing in each direction.

Bearings mounted back-to-back provide a relatively stiff bearing arrangement that can also accommodate tilting moments.

### Face-to-face bearing arrangements

In a face-to-face arrangement (→ **fig. 1**), the load lines converge toward the bearing axis. Axial loads acting in both directions can be accommodated, but only by one bearing in each direction. Bearing sets in face-to-face arrangements are less suited to accommodate tilting moments than those in a back-to-back arrangement.

Fig. 1

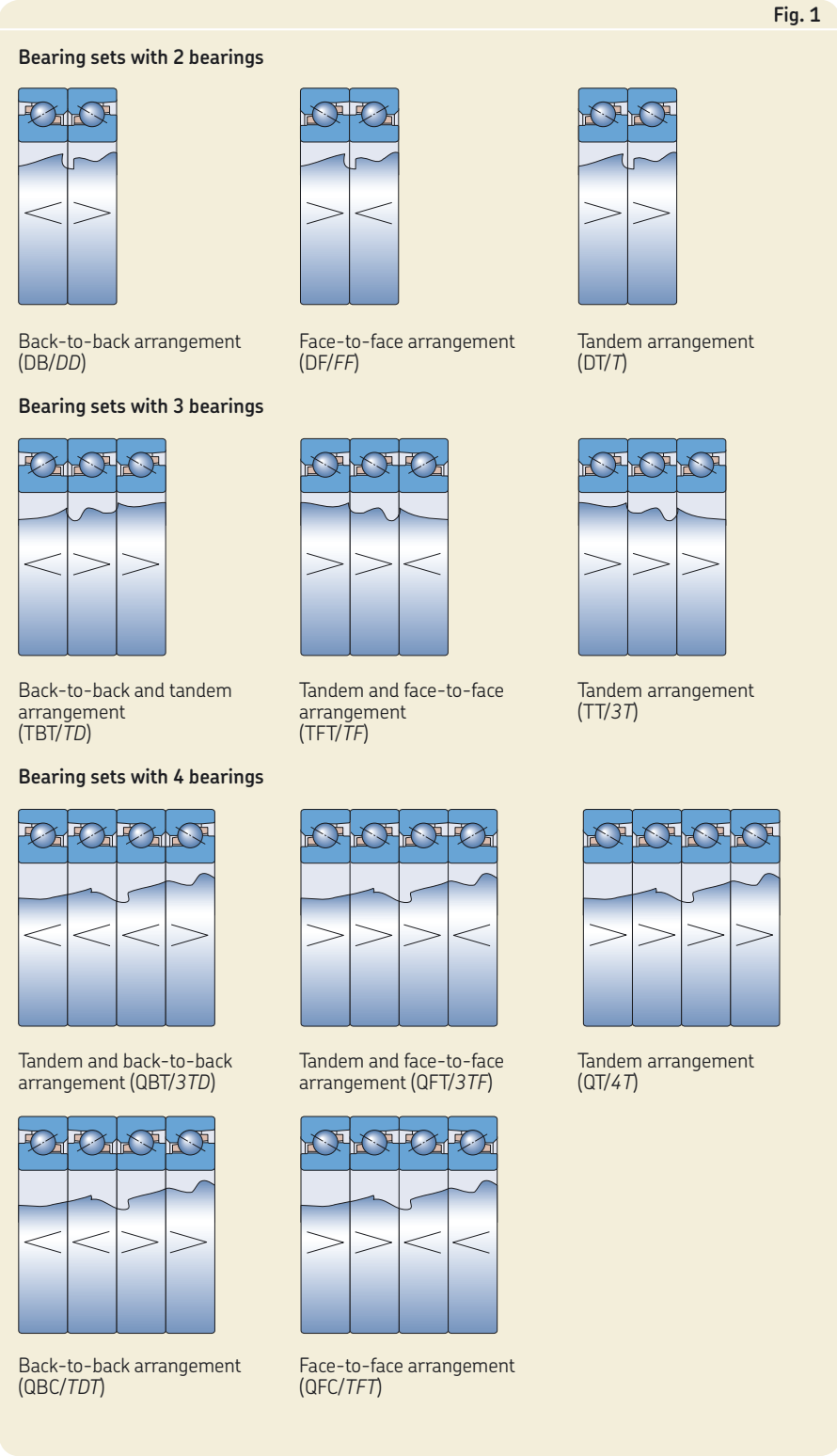

## Tandem bearing arrangements

In a tandem arrangement (→ **fig. 1, page 19**), the load lines are parallel to each other. The radial and axial loads are equally shared by the bearings. The bearing set can only accommodate axial loads acting in one direction and is therefore typically used with another bearing or another bearing set that accommodates the axial loads in the opposite direction.

## Other bearing arrangements

Combinations of tandem arrangements with back-to-back or face-to-face arrangements (→ **fig. 1**) are usually selected to maximize the stiffness or load carrying ability of a bearing set in a particular direction. This is the case, for example, when extended, preloaded, vertical or overhung screw drives must be supported.

## Accommodating misalignment

If misalignment cannot be avoided between the bearing positions, face-to-face bearing sets are recommended. They are less sensitive to misalignment than back-to-back bearing sets.

## Bearings for the non-locating position

If temperature differences between the screw drive and machine bed require a non-locating bearing in one position, needle roller bearings are suitable, among others. In this case, only the weight of the screw drive loads the bearing, making it unnecessary to calculate the bearing life.

## Associated components

Associated components should be produced very precisely so that super-precision angular contact thrust ball bearings can meet the demands for high running accuracy. All dimension and form deviations must be kept as low as possible for associated components. The bearing seats on the screw drive and the seats in the housing bore should follow the recommended tolerances listed in **tables 5 to 7**.

Table 5

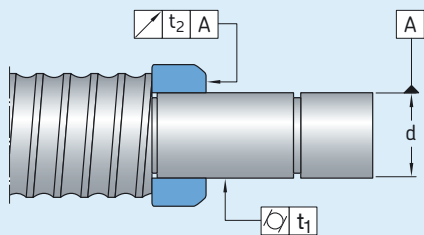

### Accuracy of seats on screw drives

Nominal diameter d	Tolerances		Cylindricity (IT2) t <sub>1</sub>	Runout (IT2) t <sub>2</sub>	
	high	low			
over	incl.				
mm		µm			
10	18	0	-5	2	2
18	30	0	-6	2,5	2,5
30	50	0	-7	2,5	2,5
50	80	0	-8	3	3

Table 6

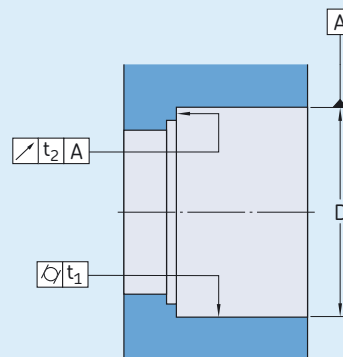

### Accuracy of seats in housings

Nominal diameter D	Tolerances		Cylindricity (IT2) t <sub>1</sub>	Runout (IT3) t <sub>2</sub>	
	high	low			
over	incl.				
mm		µm			
-	50	+11	0	2,5	4
50	80	+13	0	3	5
80	120	+15	0	4	6
120	150	+18	0	5	8



Table 7

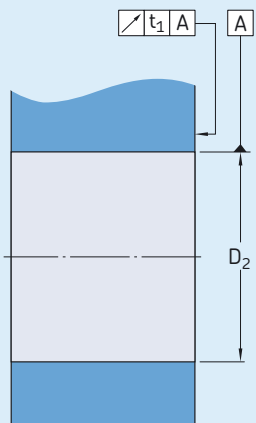

**Accuracy of the housing bore and sidefaces for bearings for bolt mounting and cartridge units**

Nominal diameter D <sub>2</sub>	incl.	Housing bore Tolerance (H6)		Sideface Axial runout (IT3)
		high	low	t <sub>1</sub>
mm		µm		µm
50	80	+19	0	5
80	120	+22	0	6
120	150	+25	0	8

Fig. 2

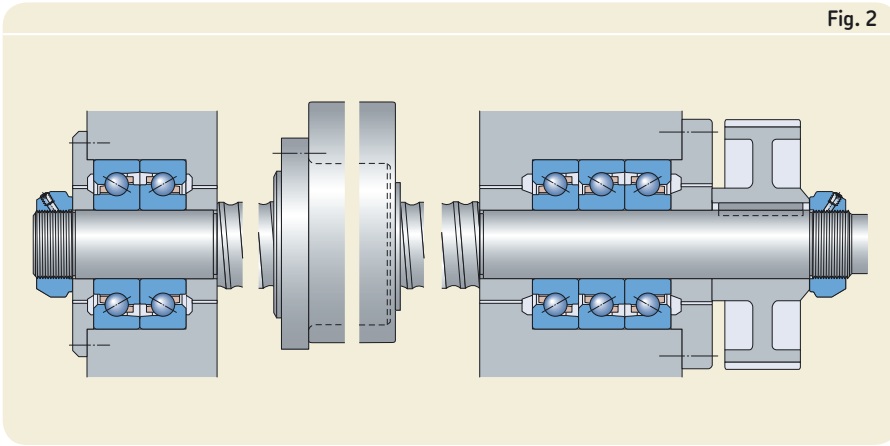
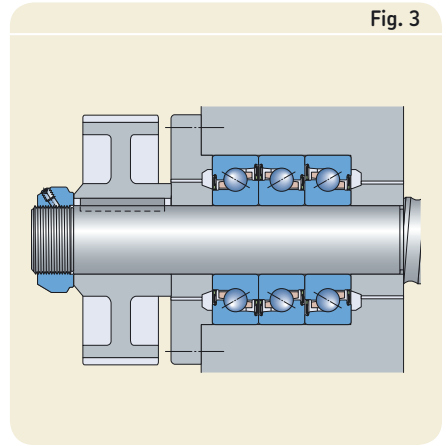

Fig. 3



## Application examples

Screw drives are typically supported at both ends with bearing sets in a face-to-face or back-to-back arrangement (→ **fig. 2**). With universally matchable single direction bearings, it is possible to adjust the arrangement to the requirements. Sealed bearings (→ **fig. 3**) offer additional benefits such as a smaller number of components or no lubrication necessary during mounting. Double direction bearings (→ **fig. 4**) enable further reduction of components. Double direction bearings for bolt mounting (→ **fig. 5**) do not require a housing and can be mounted easily.

For short screw drives, an overhung support at one end is common (→ **fig. 6**). Back-to-back arrangements are best suited for overhung supports.

For stretched screw drives particularly, stiff bearing arrangements, can be designed if two tandem arrangements are used at both ends that are adjusted against each other (→ **fig. 7**). Cartridge units are beneficial for these cases.

Fig. 4

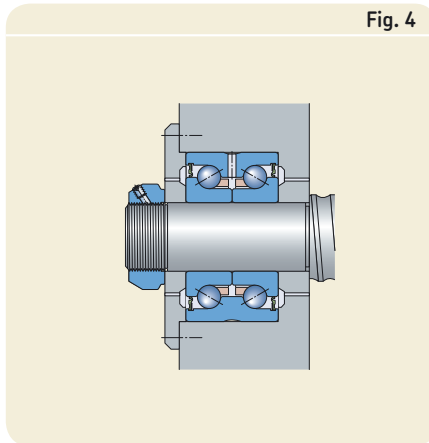

Fig. 5

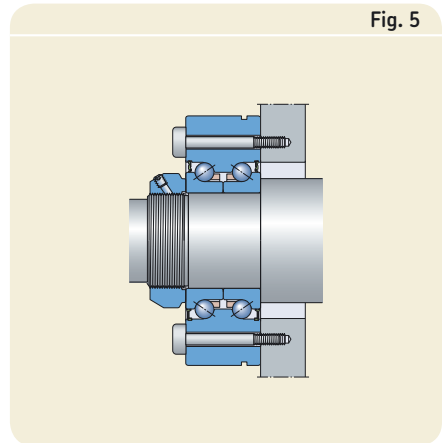

Fig. 6

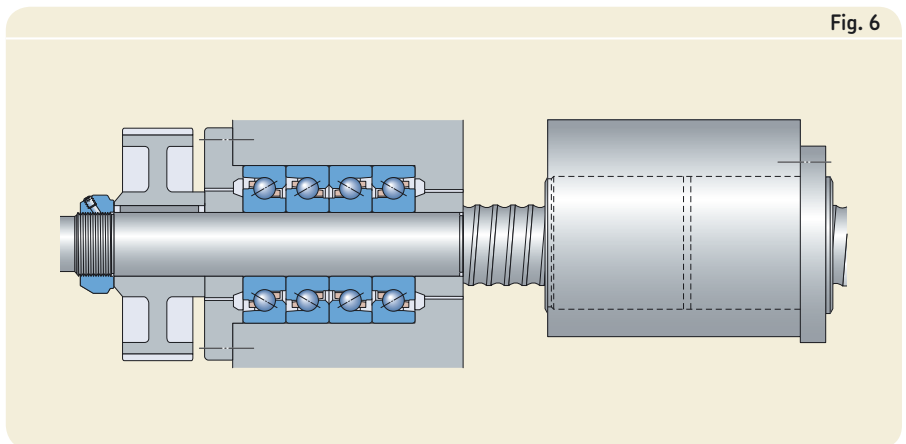
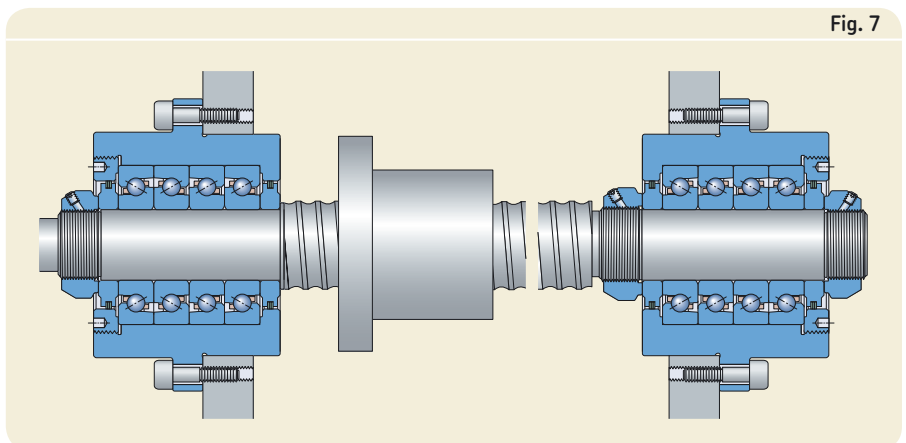

Fig. 7



# Lubrication

Open single direction bearings can be lubricated with grease or oil. In general, however, grease lubrication is preferred as it simplifies the design and maintenance of the bearing arrangement. Sealed single direction bearings, double direction bearings and cartridge units are supplied already greased. Under normal operating conditions, the service life of the initial fill will outlast the bearing. If double direction bearings have to accommodate heavy loads and run for long periods at high speeds, relubrication may be necessary.

Proper lubrication is a prerequisite for reliable bearing performance. For detailed recommendations about grease type and quantity, contact the application engineering service.

## Greasing open bearings

For most operating conditions, a calcium complex soap grease based on ester/mineral oil is recommended. For relatively low speeds and heavily loaded screw drive bearings that are exposed to vibration during operation, a lithium soap grease with a mineral base oil and EP additives like SKF LGEP 2 should be used. Note that greases with a high viscosity base oil increase friction and heat generated by the bearing but provide excellent protection against false brinelling.

## Grease quantity

Open single direction bearings should be lubricated with a grease quantity that fills approximately 25 to 35 % of the free space in the bearing. Guideline values for suitable grease quantities are listed in **table 8**.

If no experience about the filling grade is available, the grease quantity for single direction bearings can be estimated using

$$G = G_{ref} K$$

where

$G$  = grease quantity for the initial fill [g] or [cm<sup>3</sup>]

$G_{ref}$  = reference grease quantity for the bearing according to **table 8** [g] or [cm<sup>3</sup>]

$K$  = factor according to **diagram 6**, (→ **page 24**) depending on the speed factor  $A = n d_m$  [mm/min]  
 $n$  = rotational speed [r/min]  
 $d_m$  = bearing mean diameter [mm] = 0,5 (d + D)

Table 8

Guideline values for grease quantity for single direction angular contact thrust ball bearings

Designations		Grease quantity for 25 to 35 % filling grade		Reference grease quantity $G_{ref}$	
SKF	SNFA	g	cm <sup>3</sup>	g	cm <sup>3</sup>
–	–	g	cm <sup>3</sup>	g	cm <sup>3</sup>
BSA 201 C	BS 212	0,3–0,5	0,3–0,4	0,66	0,7
BSA 202 C	BS 215	0,4–0,6	0,4–0,5	0,80	0,85
BSA 203 C	BS 217	0,5–0,7	0,4–0,6	0,94	1
BSA 204 C	BS 220	0,8–1,2	0,8–1,1	1,7	1,8
BSA 205 C	BS 225	1,1–1,5	1–1,4	2,1	2,2
BSA 206 C	BS 230	1,5–2,1	1,4–2	3,0	3,2
BSA 207 C	BS 235	2–2,8	1,9–2,7	4,0	4,3
BSA 208 C	BS 240	2,5–3,6	2,4–3,3	5,1	5,4
BSA 209 C	BS 245	3,1–4,3	2,9–4,1	6,2	6,5
BSA 210 C	BS 250	3,5–5	3,3–4,7	7,1	7,5
BSA 212 C	BS 260	5,7–8	5,4–7,5	11,4	12,1
BSA 215 C	BS 275	7,5–10,5	7–9,8	14,9	15,9
BSA 305 C	BS 325	1,6–2,3	1,5–2,2	3,3	3,5
BSA 306 C	BS 330	1,5–2	1,4–1,9	2,9	3,1
BSA 307 C	BS 335	2,8–3,9	2,7–3,7	5,6	6
BSA 308 C	BS 340	4,3–6,1	4,1–5,7	8,7	9,2
BSD 2047 C	BS 20/47	1–1,3	0,9–1,3	1,9	2
BSD 2562 C	BS 25/62	1,4–1,9	1,3–1,8	2,8	2,9
BSD 3062 C	BS 30/62	1,4–1,9	1,3–1,8	2,8	2,9
BSD 3572 C	BS 35/72	1,7–2,4	1,6–2,2	3,4	3,6
BSD 4072 C	BS 40/72	1,7–2,4	1,6–2,2	3,4	3,6
BSD 4090 C	BS 40/90	3,5–4,9	3,3–4,6	7,1	7,5
BSD 4575 C	BS 45/75	1,8–2,6	1,7–2,4	3,7	3,9
BSD 45100 C	BS 45/100	4–5,6	3,8–5,3	8,0	8,5
BSD 50100 C	BS 50/100	4,4–6,2	4,1–5,8	8,8	9,3
BSD 55100 C	BS 55/100	4,4–6,2	4,1–5,8	8,8	9,3
BSD 55120 C	BS 55/120	5,1–7,1	4,8–6,7	10,2	10,8
BSD 60120 C	BS 60/120	5,1–7,1	4,8–6,7	10,2	10,8

## Example

A bearing BSA 207 C (BS 235) is running at 3 000 r/min. How much grease should be applied?

Obtained from the product table:  $d = 35$ ,  $D = 72$ ; calculated:  $A = 3\,000 \times (35 + 72)/2 = 160\,500$  mm/min; obtained from **diagram 6** for  $A = 0,16 \times 10^6$  mm/min,  $K = 0,81$ ; obtained from **table 8**,  $G_{ref} = 4,3$  cm<sup>3</sup>; calculated:  $G = 4,3 \times 0,81 = 3,5$  cm<sup>3</sup>.

## Applying grease

When greasing bearings, the grease should be distributed evenly in the free space between the balls and bearing rings. The bearings should be turned by hand until all internal surfaces are covered by a layer of grease.

Small bearings often require very small quantities of grease. When a very small grease quantity has to be applied, the bearing should be immersed in a grease solution (3 to 5 % grease in a solvent) first. The grease solution must drain and the solvent must evaporate before applying the grease. Immersing in a grease solution ensures that all surfaces are covered with a thin layer of the lubricant.

## Relubrication

### Single direction bearings and cartridge units

If relubrication is required, the bearings should be dismantled and washed before new grease is applied.

### Double direction bearings

Double direction bearings can be relubricated via lubrication holes in the outer ring. When relubricating, the application should ideally be at normal operating temperature and the bearing should be rotating. The grease should be applied slowly until fresh grease escapes from the seal. Excessive pressure should be avoided as this could damage the seals.

## Running-in of grease lubricated bearings

A grease lubricated super-precision bearing will initially run with a higher frictional moment. If the bearing is run at high speed without a running-in period, the temperature rise can be considerable and perhaps damage the grease. The high frictional moment is due to the churning of the grease and it takes time for the excess grease to work its way out of the contact zone. The grease that collects at the sides of the bearing will act as a reservoir and the oil will bleed into the raceways to provide efficient lubrication for a long time.

The time required to stabilize the operating temperature depends on a number of factors such as the type of grease, the grease fill, how the grease is applied to the bearing(s), the bearing type and internal design, and the running-in procedure. Bearings typically work with minimal lubricant when properly run-in, enabling the lowest frictional moment and temperature to be achieved.

Running-in can be done in several ways. Wherever possible and regardless of the procedure chosen, running-in should involve operating the bearing in both a counterclockwise position. The standard running-in procedure is time consuming. The total time for the running-in process could be as high as 8–10 hours. The short running-in procedure reduces the number of stages. Although each stage may have to be repeated several times, each cycle is just a few minutes long. The total time for this running-in process is substantially less than with the standard procedure.

Diagram 6

Factor K for initial grease fill estimation

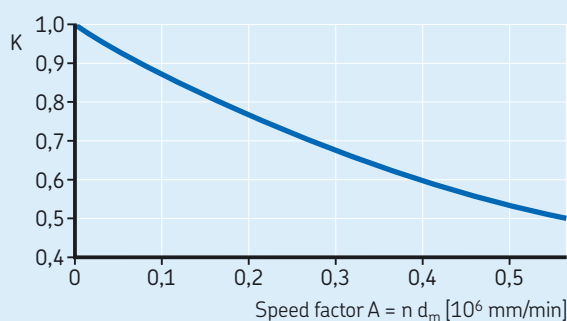

## Standard running-in procedure

This is the most common running-in procedure and can be summarized as follows:

- 1 Select a low starting speed and a relatively small speed increment interval.
- 2 Decide on an absolute temperature limit, usually 60 to 65 °C. It is advisable to set the machine with limit switches that will stop the spindle if the temperature rise exceeds the limits set.
- 3 Start operation at the chosen initial speed.
- 4 Monitor the temperature by taking measurements at the bearing outer ring position avoiding peaks, and wait for it to stabilize. If the temperature reaches the limit, stop operation and allow the bearing to cool. Start again at the same speed and wait for the temperature to stabilize.
- 5 Increase the speed by one interval and repeat **step 4**.
- 6 Continue increasing the speed in intervals, allowing the temperature to stabilize below the limit at each stage. Proceed until this is achieved for one speed interval greater than the operating speed of the system. This results in a lower temperature rise during normal operation. The bearing is now properly run-in.

## Short running-in procedure

The main steps of the short running-in procedure can be summarized as follows:

- 1 Select a starting speed that is approximately 20–25 % of the attainable speed and choose a relatively large speed increment interval.
- 2 Decide on an absolute temperature limit, usually 60 to 65 °C. It is advisable to set the machine with limit switches that will stop the spindle if the temperature rise exceeds the limits set.
- 3 Start operation at the chosen initial speed.
- 4 Monitor the temperature by taking measurements at the bearing outer ring position until the temperature reaches the limit. Care should be taken as the temperature increase may be very rapid.
- 5 Stop operation and let the outer ring of the bearing cool down by 5 to 10 °C.
- 6 Start operation at the same speed a second time and monitor the temperature until the limit is reached again.
- 7 Repeat **steps 5** and **6** until the temperature stabilizes below the limit. When the temperature peak is lower than the alarm limit, the bearing is run-in at that particular speed.
- 8 Increase the speed by one interval and repeat **steps 4** to **7**.
- 9 Proceed until the bearing is running at one speed interval greater than the operating speed of the system. This results in a lower temperature rise during normal operation. The bearing is now properly run-in.

# Single direction angular contact thrust ball bearings

SKF single direction angular contact thrust ball bearings (→ **fig. 1**) are designed to accommodate heavy axial loads. The bearings only accommodate axial loads in one direction and are therefore adjusted against a second bearing or mounted as bearing sets. Key features include:

- 62° contact angle
- robust, window-type polyamide 66 cage
- universally matchable in any order, in sets with up to four bearings
- non-separable

Single direction angular contact thrust ball bearings for screw drives are only produced as universally matchable bearings, but they can also be used for bearing arrangements with only one bearing in each position.

## Matched bearing sets

SKF single direction angular contact thrust ball bearings can be supplied on request as matched bearings sets comprising two, three or four bearings. Because the bearings are universally matchable as standard with tight tolerances for the bore and the outside diameter, it is recommended to order single bearings only and arrange them in sets as required.

## Sealed bearings

SKF single direction angular contact thrust ball bearings are available with a low-friction seal on both sides of the bearing (→ **fig. 2**). The seals are made of an oil and wear-resistant acrylonitrile-butadiene rubber (NBR) and are steel reinforced. The material tolerates short-term dry running of the sealing lip.

The operating temperature range for these seals is -40 to +100 °C and up to +120 °C for brief periods. At higher temperatures, the material hardens. Sealed single direction bearings have 25 to 35 % of the free space filled at the factory with a lithium soap grease based on mixed ester/PAO oil. The temperature range for the grease is -40 to +120 °C.

For more information about sealed bearings, contact the application engineering service.

## Greased bearings

Open SKF single direction angular contact thrust ball bearings can be supplied factory-greased. The standard grease is the same as for sealed bearings, but customer specific greases or fill quantities can be applied. Factory-greased open bearings with the standard grease are marked with the designation suffix GMM.

Fig. 1

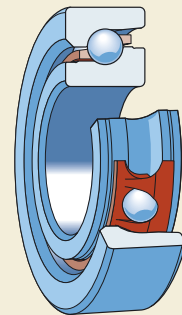
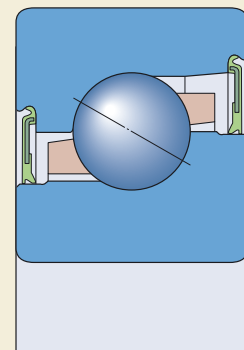

Fig. 2





# Double direction angular contact thrust ball bearings

SKF double direction angular contact thrust ball bearings for screw drives in the BEAS series (→ **fig. 3**) correspond in design to two single direction bearings arranged back-to-back. Double direction angular contact thrust ball bearings are non-separable and have

- a one-piece outer ring
- a two-piece inner ring
- a polyamide 66 cage
- a seal on both sides
- a 60° contact angle

They are available with contact seals (designation suffix 2RS or C, → **fig. 4a**) or non-contact shields (designation suffix 2Z or Z, → **fig. 4b**). The seals are made of an oil and wear-resistant acrylonitrile-butadiene rubber (NBR) and are sheet steel reinforced. The operating temperature range for these seals is -40 to +100 °C and up to +120 °C for brief periods.

The bearings are filled as standard with a high-grade, low-viscosity lithium soap grease with ester oil as its base. The quantity of grease fills some 25 to 35 % of the free space in the bearing. Under normal operating conditions, the service life of the initial fill will outlast the bearing. The temperature range for the grease is -55 to +110 °C.

Sealed bearings are ready-to-mount. They should not be washed or heated above 80 °C. Heat should only be applied using an induction heater that rapidly heats the bearing rings, without affecting non-metallic components like the cage.

All bearings have an annular groove and lubrication holes in the outer ring, to relubricate the bearings easily and reliably, if required.

The preload set at the factory is produced for these bearings by pressing the two inner ring halves together, e.g. with a precision lock nut that also holds the bearing at the end of the screw drive. The preload, combined with design features stated above, provide high axial stiffness and also make these bearings suitable for accommodating radial loads.

Fig. 3

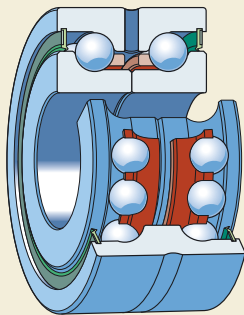
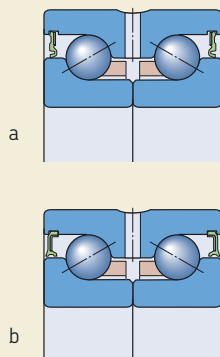

Fig. 4



# Double direction angular contact thrust ball bearings for bolt mounting

SKF double direction angular contact thrust ball bearings in the BEAM series (→ **fig. 5**) are intended for bolt mounting and are typically used when space is tight or quick mounting is required. They correspond in design to the BEAS series bearings, except that the outer ring is much thicker and equipped with through holes for attachment bolts. By bolting directly onto an associated component, the design and mounting process are simplified.

To enable relubrication, if required, one sideface and the bearing outside surface have a M6 threaded hole. The holes are plugged on delivery with a set screw. The sideface with the threaded hole should be mounted opposite the machine wall. PE (SQ) design bearings do not have a threaded hole on the outside surface of the bearing and can only be relubricated via the threaded hole in the sideface.

BEAM series bearings have an annular groove on their outside surface that can be used to dismount the bearing from its seat on the screw drive.

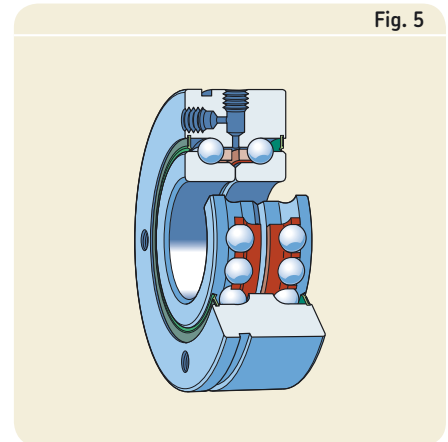

# Cartridge units with a flanged housing

SKF single direction angular contact thrust ball bearings are also available as ready-to-mount flanged cartridge units (→ **fig. 6**). These cartridge units, which can accommodate heavy axial loads, have been designed for screw drive applications requiring a high degree of stiffness and quick mounting. Cartridge units are available with different bearing arrangements:

- two bearings in a back-to-back arrangement (→ **fig. 7a**), series designation **FBSA .. DB (BSDU .. DD)**
- two bearings in a face-to-face arrangement (→ **fig. 7b**), series designation **FBSA .. DF (BSDU .. FF)**
- two bearing pairs in a back-to-back arrangement (→ **fig. 8a**), series designation **FBSA .. QBC (BSQU .. TDT)**
- two bearing pairs in a face-to-face arrangement (→ **fig. 8b**), series designation **FBSA .. QFC (BSQU .. TFT)**

There are also cartridge units with four bearings, where the flange is positioned differently (→ **fig. 6c**):

- series designation **FBSA .. A/QBC (BSQU ...1/TDT)**
- series designation **FBSA .. A/QFC (BSQU ...1/TFT)**

Cartridge units with different bearing arrangements or preload are available on request. The units are lubricated with a low-viscosity grease and are ready-to-mount. The quantity of grease fills some 25 to 35 % of the free space in the bearing. Under normal operating conditions, the service life of the initial fill will outlast the bearings.

Cartridge units should be located at the end of the screw drive with an SKF KMT precision lock nut and bolted to the machine wall.

The flanged housings are made of high-quality steel and protected on both sides with a laminar seal to prevent both the ingress of contaminants and grease leakage. These seals do not limit the attainable speed for single direction angular contact thrust ball bearings.

Fig. 6

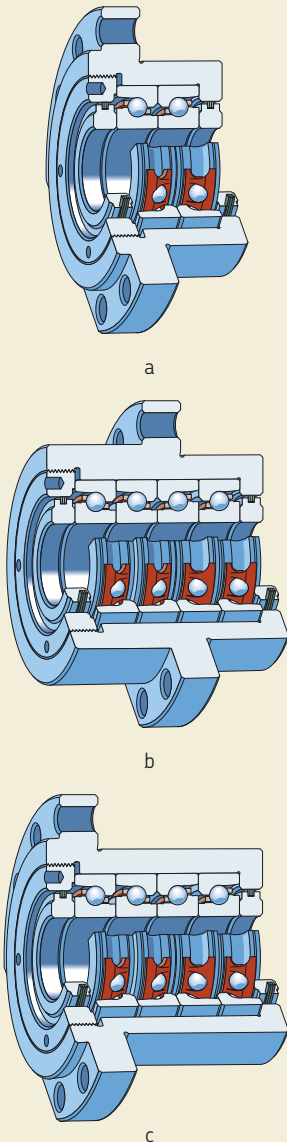

Fig. 7

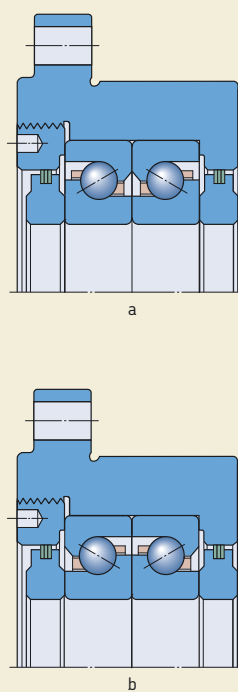
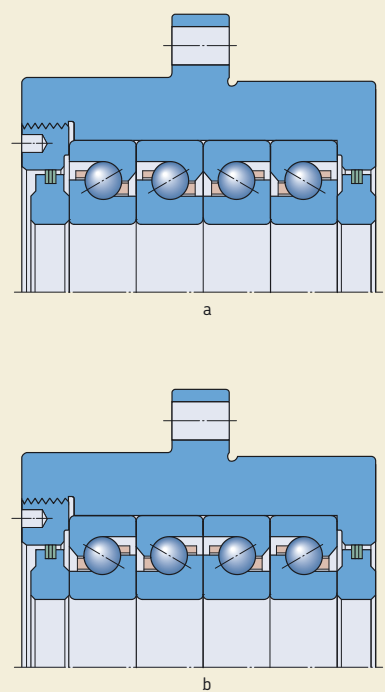

Fig. 8



# Bearing data – general

## Dimensions

The boundary dimensions of SKF single direction angular contact thrust ball bearings in the BSA 2 (BS 2) and BSA 3 (BS 3) series are in accordance with the values for Dimension Series 02 and 03 in accordance with ISO 15:1998.

The dimensions of the other bearings and bearing units are not standardized, but are common in the market.

## Tolerances

SKF angular contact thrust ball bearings for screw drives are produced as standard with the tolerances listed in **table 1**. They meet class P4 tolerances for dimensional accuracy and class P2 tolerances for running accuracy for radial bearings in accordance to ISO 492:2002, respective ABEC 7 precision class.

The values stated for single direction bearings apply to individual bearings. For matched bearing sets, the axial runout is usually within 2,5 µm if the bearing seats are machined precisely and the bearings are mounted properly.

Cartridge units with a flanged housing for screw drives are produced to the tolerances listed in **table 2**.

## Preload in unmounted bearings

### Single direction bearings

For SKF single direction angular contact thrust ball bearings used as individual bearings, the preload is only obtained after mounting and depends on its adjustment against a second bearing or bearing set, which provides axial location in the opposite direction.

Universally matchable bearings for mounting in sets are supplied in preload classes listed in **table 3**.

Table 1

### Tolerances of angular contact thrust ball bearings for screw drives

#### Inner ring and bearing height

d over	incl.	Single direction bearings				Double direction bearings					
		$\Delta_{ds}$ , high	$\Delta_{dmp}$ low	$\Delta_{Ts}$ high	low	$S_{ia}$ max	$\Delta_{ds}$ , high	$\Delta_{dmp}$ low	$\Delta_{Bs}$ high	low	$S_{ia}$ max
mm		µm		µm		µm	µm		µm		µm
10	18	0	-4	0	-80	1,5	0	-5	0	-250	2
18	25	0	-4	0	-120	2,5	0	-5	0	-250	2
25	30	0	-4	0	-120	2,5	0	-5	0	-250	2,5
30	50	0	-5	0	-120	2,5	0	-5	0	-250	2,5
50	60	0	-5	0	-120	2,5	0	-8	0	-250	2,5
60	80	0	-5	0	-120	2,5	0	-8	0	-250	3

#### Outer ring

D over	incl.	Single direction bearings				Double direction bearings					
		$\Delta_{Ds}$ , high	$\Delta_{Dmp}$ low	$S_{ea}$ max		$\Delta_{Ds}$ , high	$\Delta_{Dmp}$ low	$\Delta_{Cs}$ high	low	$S_{ea}$ max	
mm		µm		µm		µm		µm		µm	
30	50	0	-5	2,5		0	-10	0	-250	5 ... 8	
50	80	0	-6	4		0	-10	0	-250	5 ... 10	
80	110	0	-6	5		0	-10	0	-250	6 ... 11	
110	120	0	-6	5		0	-15	0	-250	6 ... 11	
120	150	0	-7	5		0	-15	0	-250	7 ... 13	

The preload values are listed in **table 4** on **page 32** and are not standardized. The values do not cover influences from its fit (shaft and housing) or operating conditions. They apply to bearing sets with two bearings in a back-to-back or face-to-face arrangement. Bearing sets with different preloads can be supplied on request.

Bearing sets consisting of three or four bearings have a higher preload than sets with two bearings. Guideline values for preload in these bearing sets are obtained by multiplying the values listed in **table 4, page 32**, by the factor of:

- 1,35 for TBT (*TD*) and TFT (*TF*) arrangements
- 1,55 for QBT (*3TD*) and QFT (*3TF*) arrangements
- 2 for QBC (*TDT*) and QFC (*TFT*) arrangements

## Double direction bearings

SKF double direction angular contact thrust ball bearings are supplied with the preload listed in **table 4**. The values do not cover influences from fits or operating conditions. Bearings with different preloads are available on request.

## Cartridge units with a flanged housing

SKF cartridge units contain bearings with preload class A as standard (→ **table 4**). Contact SKF for availability of bearing units with class B or special preload.

## Frictional moment

All SKF angular contact thrust ball bearings for screw drives are designed for low friction operation. The frictional moment depends on the preload, operational speed and quantity of lubricant in the bearing set and increases accordingly.

The guideline values for the frictional moment listed in **table 4** apply to unmounted bearings that will operate at low speeds. The starting torque is typically double the frictional moment size.

Bearing sets, consisting of three or four bearings, have a higher frictional moment than sets with two bearings. The frictional moment for these bearings can be calculated by multiplying the values listed in **table 4** by a factor of:

- 1,35 for TBT (*TD*) and TFT (*TF*) arrangements
- 1,55 for QBT (*3TD*) and QFT (*3TF*) arrangements
- 2 for QBC (*TDT*) and QFC (*TFT*) arrangements

Guideline values for the frictional moment in cartridge units are listed in the product table.

## Lifting force

External axial loads can change the preload in a bearing set or double direction bearing, causing one ball set to become heavily loaded, leaving the other ball set without its requisite load. The force used to describe this phenomenon is called lifting force.

When the axial load reaches the lifting force, the balls in the unloaded ball set start to slide in the raceway, which can cause smearing and eventual bearing failure.

A guideline value for the lifting force is obtained by multiplying the current preload by a factor of 2,8. This guideline value applies to bearing sets with two bearings in a back-to-back or face-to-face arrangement and to double direction bearings. The lifting force, for example, for a bearing or bearing pair preloaded to 1 000 N is:  $2,8 \times 1\,000 = 2\,800$  N.

For additional information, contact the application engineering service.

Table 3

### Preload classes for universally matchable bearings

Preload class SKF	SNFA	Explanation
A	M	Light preload
B	F	Moderate preload
G ...	...daN	Special execution, preload value [daN = 10 N]

Table 2

### Tolerances of cartridge units with a flanged housing

d over	Incl.	$\Delta_{ds^*}$ high	$\Delta_{dmp}$ low	$\Delta_{D2}$ high	low	$\Delta_{fs}$ high	low	$S_{ia}^{1)}$ max
mm		$\mu\text{m}$		$\mu\text{m}$		mm		$\mu\text{m}$
18	30	0	-4	0	-13	0	-1,5	2,5
30	50	0	-5	0	-15	0	-1,5	2,5
50	60	0	-5	0	-18	0	-1,5	2,5

<sup>1)</sup> Axial runout of a single bearing.

The tolerance for the rectangularity of the flange to the housing seat diameter  $D_2$  is 5 to 10  $\mu\text{m}$  depending on the size.

# Axial load carrying ability

With increasing axial load, the contact conditions in the bearing change. The pressure angles, especially the pressure ellipses, are larger and there may be increased stress in the shoulder/ raceway transition on the bearing rings. This stress is kept to a minimum for SKF bearings by appropriate measures, such as rounded and ground transition zones. Even so, the guideline values listed in **table 4** for the maximum axial load should not be exceeded.

## Cages

SKF angular contact thrust ball bearings for screw drives have cages that match the operating conditions – high accelerations and decelerations (→ **fig. 9**). Depending on the series, these bearings are equipped with either a ball guided window-type or a snap-type cage made of glass-fibre reinforced polyamide 66. These cages are particularly light to minimize centrifugal forces and can be used at operating temperatures up to +120 °C – much higher than temperatures typically occurring in machine tool applications.

The lubricants generally used in machine tools do not have a detrimental effect on the cage properties, with the exception of a few synthetic oils or greases with a synthetic oil base. For more information about the suitability of polyamide cages, contact the application engineering service.



Fig. 9

Table 4

### Single and double direction bearings: Axial preload, frictional moment and maximum axial load

Designations		Axial preload		Frictional moment <sup>1)</sup>		Maximum axial load
SKF	SNFA	Preload class A	Preload class B	Preload class A	Preload class B	
–		N		Nm		kN
<b>Single direction bearings</b>						
BSA 201	BS 212	650	1 300	0,016	0,028	6,25
BSA 202	BS 215	770	1 540	0,022	0,038	8,5
BSA 203	BS 217	1 040	2 080	0,04	0,072	10,3
BSA 204	BS 220	1 480	2 960	0,05	0,091	14,5
BSA 205	BS 225	1 580	3 160	0,069	0,12	18
BSA 206	BS 230	2 150	4 300	0,12	0,21	22,6
BSA 207	BS 235	2 950	5 900	0,18	0,32	29,6
BSA 208	BS 240	3 400	6 800	0,212	0,46	37,9
BSA 209	BS 245	3 750	7 500	0,23	0,52	40,2
BSA 210	BS 250	4 100	8 200	0,31	0,68	42,5
BSA 212	BS 260	6 050	12 100	0,54	1,05	65
BSA 215	BS 275	6 850	13 700	0,65	1,4	76
BSA 305	BS 325	2 150	4 300	0,12	0,21	22,6
BSA 306	BS 330	3 000	6 000	0,175	0,32	46
BSA 307	BS 335	4 100	8 200	0,26	0,46	65
BSA 308	BS 340	5 100	10 200	0,35	0,62	78,2
BSD 2047	BS 20/47	1 480	2 960	0,05	0,091	14,5
BSD 2562	BS 25/62	2 150	4 300	0,115	0,21	22,6
BSD 3062	BS 30/62	2 150	4 300	0,125	0,215	22,6
BSD 3572	BS 35/72	2 950	5 900	0,18	0,32	29,6
BSD 4072	BS 40/72	2 950	5 900	0,18	0,32	29,6
BSD 4090	BS 40/90	5 100	10 200	0,35	0,61	78,2
BSD 4575	BS 45/75	2 900	5 800	0,25	0,41	40,2
BSD 45100	BSD 45/100	5 850	11 700	0,5	0,97	107,4
BSD 50100	BS 50/100	6 200	12 400	0,52	0,97	107,4
BSD 55100	BS 55/100	6 200	12 400	0,52	0,97	107,4
BSD 55120	BS 55/120	7 300	14 600	0,72	1,26	130
BSD 60120	BS 60/120	7 300	14 600	0,72	1,26	130
<b>Double direction bearings</b>						
BEAS 008032	BEAS 8/32	300	–	0,08	–	–
BEAS 012042	BEAS 12/42	600	–	0,16	–	–
BEAS 015045	BEAS 15/45	650	–	0,2	–	–
BEAS 017047	BEAS 17/47	720	–	0,24	–	–
BEAS 020052	BEAS 20/52	1 650	–	0,3	–	–
BEAS 025057	BEAS 25/57	1 920	–	0,4	–	–
BEAS 030062	BEAS 30/62	2 170	–	0,54	–	–
BEAM 012055	BEAM 12/55	600	–	0,16	–	–
BEAM 017062	BEAM 17/62	700	–	0,24	–	–
BEAM 020068	BEAM 20/68	1 650	–	0,3	–	–
BEAM 025075	BEAM 25/75	1 920	–	0,4	–	–
BEAM 030080	BEAM 30/80	2 170	–	0,5	–	–
BEAM 030100	BEAM 30/100	3 900	–	0,8	–	–
BEAM 035090	BEAM 35/90	2 250	–	0,6	–	–
BEAM 040100	BEAM 40/100	2 550	–	0,7	–	–
BEAM 040115	BEAM 40/115	4 750	–	1,3	–	–
BEAM 050115	BEAM 50/115	3 100	–	0,69	–	–
BEAM 050140	BEAM 50/140	5 720	–	2,6	–	–
BEAM 060145	BEAM 60/145	4 700	–	2	–	–

<sup>1)</sup> The guideline values for the frictional moment for the double direction bearings in the BEAS and BEAM series apply to bearings with seals (designation suffix 2RS). For bearings with shields (designation suffix 2Z) the frictional moment is only half.



## Load ratings for bearing sets

The dynamic load rating  $C$  and the static load rating  $C_0$ , as well as the fatigue load limit  $P_u$  listed in the product table for single direction bearings apply to axial loads for individual bearings. For bearing sets, the relevant values to be applied are listed in **table 5**.

## Equivalent dynamic bearing load

If individual single direction bearings, bearing sets or double direction bearings have to accommodate both radial and axial loads, the equivalent dynamic bearing load for each direction of axial load is obtained from:

$$P = X F_r + Y F_a \quad \text{for } F_a/F_r \leq 2,35$$

$$P = 0,97 F_r + F_a \quad \text{for } F_a/F_r > 2,35$$

For bearings that accommodate axial loads only:

$$P = F_a$$

where

$P$  = equivalent dynamic bearing load [kN]

$F_r$  = actual radial bearing load [kN]

$F_a$  = actual axial bearing load [kN]

$X$  = radial load factor of the bearing, for single direction bearings according to **table 5**, for double direction bearings  $X = 1,9$

$Y$  = axial load factor of the bearing for single direction bearings according to **table 5**, for double direction bearings  $Y = 0,55$

Preload should be taken into account as axial load. For bearing sets in any arrangement, the equivalent bearing load must be calculated separately for both load directions.

## Equivalent static bearing load

If individual single direction bearings, bearing sets or double direction bearings have to accommodate both radial and axial loads, the equivalent static bearing load for each direction of axial load is obtained from:

$$P_0 = F_a + 4,35 F_r$$

where

$P_0$  = equivalent static bearing load [kN]

$F_a$  = actual axial bearing load [kN]

$F_r$  = actual radial bearing load [kN]

Preload should be taken into account as axial load. For bearing sets in any arrangement, the equivalent bearing load must be calculated separately for both load directions.

The equation for equivalent static bearing load also applies to individual bearings and for bearings in a tandem arrangement if the load ratio  $F_a/F_r$  is not lower than 4. For  $F_a/F_r$ , between 4 and 2,5, the equation still provides usable approximation values.

Table 5

Load ratings, fatigue load limit and calculation factors for bearing sets with single direction bearings

Number of bearings per set	Arrangement		Symbol	Load direction	Load rating of bearing set		Fatigue load limit of bearing set	Calculation factors	
	Designation	suffixes			dynamic	static		X	Y
	SKF	SNFA							
2	DB	DD	<>	→	C	$C_0$	$P_u$	2,04	0,54
	DF	FF	>>	→	C	$C_0$	$P_u$	2,04	0,54
	DT	T	<<	→	1,63 C	$2 C_0$	$2 P_u$	–	–
3	TBT	TD	<>>	→	C	$C_0$	$P_u$	1,54	0,75
			<>>	←	1,63 C	$2 C_0$	$2 P_u$	2,5	0,33
	TFT	TF	>><	←	C	$C_0$	$P_u$	1,54	0,75
			>><	→	1,63 C	$2 C_0$	$2 P_u$	2,5	0,33
	TT	3T	<<<	→	2,16 C	$3 C_0$	$3 P_u$	–	–
	4	QBT	3TD	<<<>	←	C	$C_0$	$P_u$	1,26
<<<>				→	2,16 C	$3 C_0$	$3 P_u$	2,71	0,25
QFT		3TF	>><<	←	C	$C_0$	$P_u$	1,26	0,87
			>><<	→	2,16 C	$3 C_0$	$3 P_u$	2,71	0,25
QBC		TDT	<<>>	→	1,63 C	$2 C_0$	$2 P_u$	2,04	0,54
QFC		TFT	>><<	→	1,63 C	$2 C_0$	$2 P_u$	2,04	0,54
QT	4T	<<<<	→	2,64 C	$4 C_0$	$4 P_u$	–	–	

# Markings on bearings

Each bearing has different codes and marks on its outside surface. **Fig. 10** shows the markings on single direction bearings, **fig. 11** shows the marking on double direction bearings, and **fig. 12** shows the markings on cartridge units. The different markings describe:

- 1 SKF trademark
- 2 Complete designation of the bearing
- 3 Country of origin
- 4 Date of manufacture, coded
- 5 "MATCHABLE" label, for single direction bearings only

There is also a "V-shaped" marking on the bearing outside surface of single direction bearings. The V points in the direction from which an axial load can be applied to the inner ring (→ **fig. 13**).

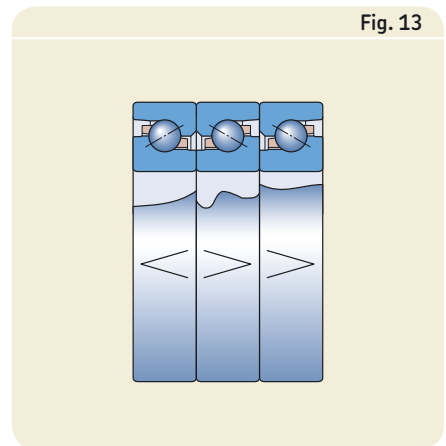
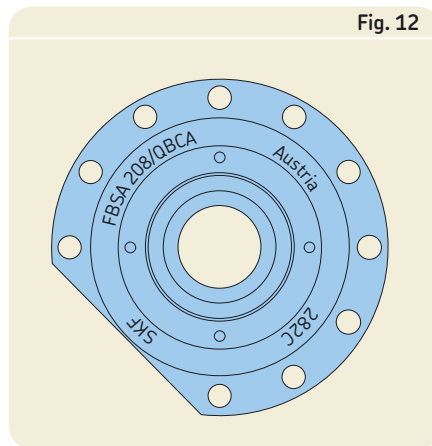
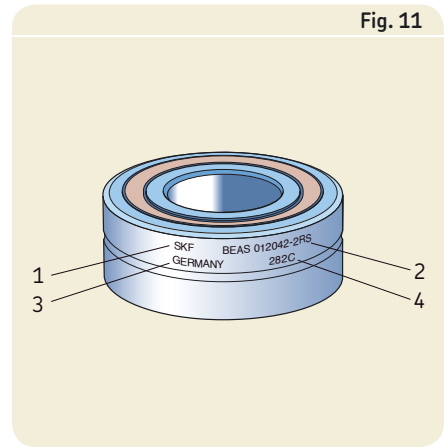
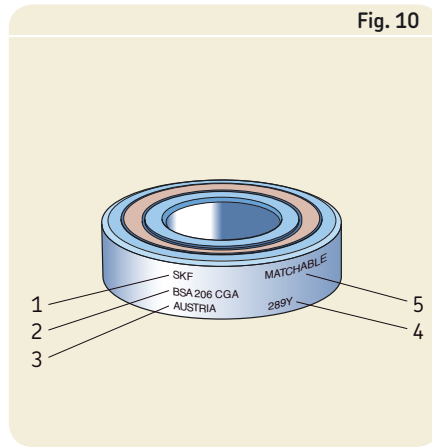

## Packaging

SKF super-precision bearings are distributed in new SKF illustrated boxes (→ **fig. 14**).

Mounting instructions are either printed on the inside of the box or added in form of a leaflet.

## Designations

The bearing designation is marked on the bearing outside surface. The designation system for angular contact thrust ball bearings for screw drives is shown in **table 6** on **pages 36** and **37**, together with the definitions.

Fig. 14



C

SKF designation system for angular contact thrust ball bearings for screw drives

BSA 205 CGB	BSA 2	05	C G		B
	Series	Size	Design features	Arrangement	Preload
FBSA 206/QFC	FBSA 2	06		QFC	

**Bearing series**

<b>BSA 2</b>	Single direction bearing in the 02 ISO Dimension Series
<b>BSA 3</b>	Single direction bearing in the 03 ISO Dimension Series
<b>BSD</b>	Single direction bearing in the 03 ISO Dimension Series
<b>BEAM</b>	Double direction bearing for bolt mounting
<b>BEAS</b>	Double direction bearing
<b>FBSA</b>	Cartridge unit with a flanged housing

**Bearing size**

**Single direction bearings according to ISO Dimension Series**

<b>01</b>	12 mm bore diameter
<b>02</b>	15 mm bore diameter
<b>03</b>	17 mm bore diameter
<b>04</b>	20 mm bore diameter
<b>05</b>	25 mm bore diameter
<b>06</b>	(x5) 30 mm bore diameter
to	
<b>15</b>	(x5) 75 mm bore diameter

**Single direction bearings, not standardized**

<b>2047</b>	20 mm bore diameter and 47 mm outside diameter
-------------	--

**Double direction bearings**

<b>060145</b>	60 mm bore diameter and 145 mm outside diameter
---------------	---

**Design features**

<b>C</b>	Improved internal design
<b>G</b>	Bearing for universal matching

**Contact angle**

–	Contact angle for single direction bearings 62°
–	Contact angle for double direction bearings 60°

**Tolerance class**

–	Dimensional accuracy to ISO tolerance class 4, running accuracy to ISO tolerance class 2
<b>PE</b>	Enlarged diameter tolerance and axial runout to P5 tolerance class for radial bearings

**Cage**

<b>TN9</b>	Injection moulded cage of polyamide 66 (not included in the bearing designation)
------------	--

**Grease fill**

<b>GMG</b>	Open single direction bearing filled with standard grease
------------	---

**Bearing arrangement**

<b>DB</b>	Two bearings arranged back-to-back <>
<b>DF</b>	Two bearings arranged face-to-face ><
<b>DT</b>	Two bearings arranged in tandem <<
<b>TBT</b>	Three bearings arranged back-to-back and tandem <>>
<b>TFT</b>	Three bearings arranged face-to-face and tandem >><
<b>TT</b>	Three bearings arranged tandem >>>
<b>QBC</b>	Four bearings arranged tandem back-to-back <<>>
<b>QFC</b>	Four bearings arranged tandem face-to-face >><<
<b>QBT</b>	Four bearings arranged back-to-back and tandem <<<>
<b>QFT</b>	Four bearings arranged face-to-face and tandem >>><
<b>QT</b>	Four bearings arranged in tandem >>>>

**Seals**

<b>2RS</b>	Sheet steel reinforced contact seal of acrylonitrile-butadiene rubber (NBR) on both sides of the bearing
<b>ZZ</b>	Shield of pressed sheet steel on both sides of the bearing
<b>2RZ</b>	Sheet steel reinforced low friction seal of acrylonitrile-butadiene rubber (NBR) on both sides of the bearing

**Preload**

n.a.	
<b>A</b>	Light preload
<b>B</b>	Moderate preload
<b>G...</b>	Special preload, value in daN = 10 N

## SNFA designation system for angular contact thrust ball bearings for screw drives

BS 225 7P62U M	BS 2	25	7 P 62 U		M
	Series	Size	Design features	Arrangement	Preload
BSQU 230 TFT	BSQU 2	30		TFT	

## Bearing series

BS 2	Single direction bearing in the O2 ISO Dimension Series
BS 3	Single direction bearing in the O3 ISO Dimension Series
BS ../..	Single direction bearing, not standardized
BEAM	Double direction bearing for bolt mounting
BEAS	Double direction bearing
BSDU, BSQU	Cartridge unit with a flanged housing

## Bearing size

## Single direction bearings according to ISO Dimension series

12	Nominal bore diameter
15	
17	
20	
25	
30	
to	
75	

## Single direction bearings, not standardized

20/47	20 mm bore diameter and 47 mm outside diameter
-------	--

## Double direction bearings

60/145	60 mm bore diameter and 145 mm outside diameter
--------	---

## Design features

n.a.	
U	Bearing for universal matching

## Contact angle

62	Contact angle 62°
60	Contact angle 60°

## Tolerance class

7	Accuracy to ABEC 7 (ISO tolerance class 4)
SQ	Enlarged diameter tolerance and axial runout to P5 tolerance class for radial bearings

## Cage

P	Injection moulded cage of polyamide 66
---	--

## Grease fill

## Bearing arrangement

DD	Two bearings arranged back-to-back <>
FF	Two bearings arranged face-to-face ><
T	Two bearings arranged in tandem <<
TD	Three bearings arranged back-to-back and tandem <>>
TF	Three bearings arranged face-to-face and tandem >><
3T	Three bearings arranged tandem >>>
TDT	Four bearings arranged tandem back-to-back <<>>
TFT	Four bearings arranged tandem face-to-face >><<
3TD	Four bearings arranged back-to-back and tandem <<<>
3TF	Four bearings arranged face-to-face and tandem >>><
4T	Four bearings arranged in tandem >>>>

## Seals

C	Sheet steel reinforced contact seal of acrylonitrile-butadiene rubber (NBR) on both sides of the bearing
Z	Shield of pressed sheet steel on both sides of the bearing
S	Sheet steel reinforced low friction seal of acrylonitrile-butadiene rubber (NBR) on both sides of the bearing

## Preload

L	Very light preload
M	Light preload
F	Moderate preload
...daN	Special preload, value in daN = 10 N

Single direction angular contact thrust ball bearings  
d 12 – 75 mm

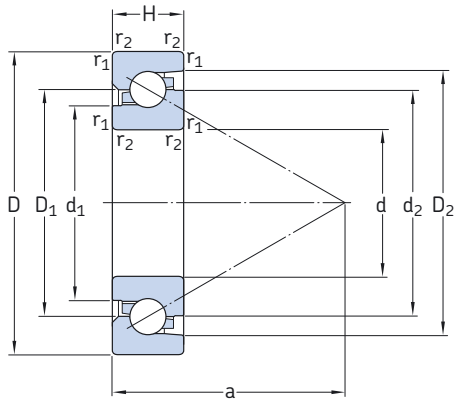

BSA ... CG-2RZ  
BSD ... CG-2RZ  
(BS ... /S 7P62U)

Principal dimensions			Basic load ratings		Fatigue load limit	Attainable speeds		Mass	Designations	SNFA
d	D	H	dynamic	static		When lubricating with grease	oil-air			
mm			C	C <sub>0</sub>	P <sub>u</sub>	r/min		kg	-	
12	32	10	11,8	21,2	0,8	14 000	17 000	0,043	BSA 201 CG	BS 212 7P62U
15	35	11	12,7	25,5	0,95	12 000	15 000	0,054	BSA 202 CG	BS 215 7P62U
17	40	12	16,6	34,5	1,27	11 000	14 000	0,078	BSA 203 CG	BS 217 7P62U
20	47	14	22	49	1,8	9 500	12 000	0,12	BSA 204 CG	BS 220 7P62U
	47	15	22	49	1,8	9 500	12 000	0,13	BSD 2047 CG	BS 20/47 7P62U
25	52	15	22,4	52	1,93	9 000	11 000	0,15	BSA 205 CG	BS 225 7P62U
	62	17	28,5	71	2,65	8 000	9 500	0,27	BSA 305 CG	BS 325 7P62U
	62	15	28,5	71	2,65	8 000	9 500	0,24	BSD 2562 CG	BS 25/62 7P62U
30	62	16	28,5	71	2,65	8 000	9 500	0,23	BSA 206 CG	BS 230 7P62U
	62	15	28,5	71	2,65	8 000	9 500	0,22	BSD 3062 CG	BS 30/62 7P62U
	72	19	40,5	98	3,65	6 700	8 000	0,40	BSA 306 CG	BS 330 7P62U
35	72	15	36,5	98	3,65	7 500	9 000	0,30	BSD 3572 CG	BS 35/72 7P62U
	72	17	36,5	98	3,65	7 500	9 000	0,33	BSA 207 CG	BS 235 7P62U
	80	21	52	129	4,75	6 000	7 000	0,56	BSA 307 CG	BS 335 7P62U
40	72	15	36,5	98	3,65	7 500	9 000	0,26	BSD 4072 CG	BS 40/72 7P62U
	80	18	42,5	112	4,15	6 300	7 500	0,43	BSA 208 CG	BS 240 7P62U
	90	20	64	170	6,3	6 000	7 000	0,68	BSD 4090 CG	BS 40/90 7P62U
	90	23	64	170	6,3	6 000	7 000	0,77	BSA 308 CG	BS 340 7P62U
45	75	15	32,5	98	3,65	7 500	9 000	0,26	BSD 4575 CG	BS 45/75 7P62U
	85	19	45	134	4,9	6 300	7 500	0,51	BSA 209 CG	BS 245 7P62U
	100	20	65,5	183	6,7	5 600	6 700	0,77	BSD 45100 CG	BSD 45/100 7P62U
50	90	20	46,5	146	5,4	6 000	7 000	0,56	BSA 210 CG	BS 250 7P62U
	100	20	67	193	7,2	5 600	6 700	0,71	BSD 50100 CG	BS 50/100 7P62U
55	100	20	67	193	7,2	5 600	6 700	0,66	BSD 55100 CG	BS 55/100 7P62U
	120	20	69,5	228	8,5	5 000	6 000	1,14	BSD 55120 CG	BS 55/120 7P62U
60	110	22	69,5	216	8	5 000	6 000	0,95	BSA 212 CG	BS 260 7P62U
	120	20	69,5	228	8,5	5 000	6 000	1,07	BSD 60120 CG	BS 60/120 7P62U
75	130	25	72	245	9,15	4 300	5 000	1,45	BSA 215 CG	BS 275 7P62U

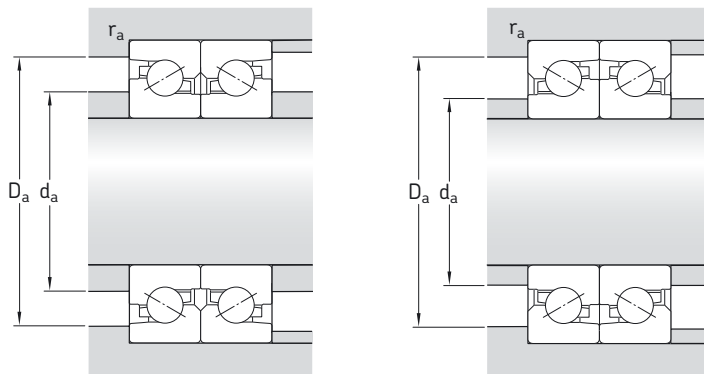

Dimensions

Abutment and fillet dimensions

d	$d_1$	$d_2$	$D_1$	$D_2$	$r_{1,2}$ min	a	$d_a$ min	$D_a$ max	$r_a$ max
mm							mm		
12	17,5	21,5	22,1	26,7	0,6	26	17	29	0,6
15	20,8	24,0	25,1	29,6	0,6	29	20	32	0,6
17	24,0	28,5	29,1	34,4	0,6	33	23	37	0,6
20	28,5	34,0	34,6	40,7	1	40	24	42	1
	28,5	34,0	34,6	40,7	1	40	27	42,5	1
25	33,0	38,0	38,6	44,7	1	44	32	47,5	1
	39,3	45,5	46,1	52,9	1	52	34	57	1
	39,3	45,5	46,1	52,9	1	51	34	57	1
30	39,3	45,5	46,1	52,9	1	51	37	57	1
	39,3	45,5	46,1	52,9	1	51	38	57	1
	43,8	50,5	51,1	59,5	1,1	57	40	65,5	1
35	48,0	54,0	55,1	62,7	1,1	59	44	64,8	1
	48,0	54,0	55,1	62,7	1,1	60	44	66	1
	49,0	58,0	58,6	69,3	1,5	66	47	72,5	1,5
40	48,0	54,0	55,1	62,7	1,1	59	47,5	65	1
	50,5	57,0	58,1	66,5	1,1	64	48	74	1
	57,0	65,5	66,6	77,3	1,5	73	53	81	1,5
	57,0	65,5	66,6	77,3	1,5	74	53	81	1,5
45	54,0	59,3	60,1	66,9	1,1	64	53	69	1
	59,3	66,5	67,1	75,4	1,1	73	53	79,5	1
	62,0	70,5	71,6	82,3	1,5	77	59	90	1,5
50	64,5	71,0	72,1	80,5	1,1	78	59	84	1
	62,0	70,5	71,6	82,3	1,5	82	65	90,5	1,5
55	62,0	70,5	71,6	82,3	1,5	82	67	91	1,5
	81,3	90,3	91,1	101,8	1,5	96	69	110	1,5
60	77,3	86,0	87,1	97,8	1,5	93	71	102	1,5
	81,3	90,3	91,1	101,8	1,5	96	73	111	1,5
75	90,3	99,1	100,1	110,7	1,5	107	85	122	1,5



**Double direction angular contact thrust ball bearings**  
**d 8 – 30 mm**

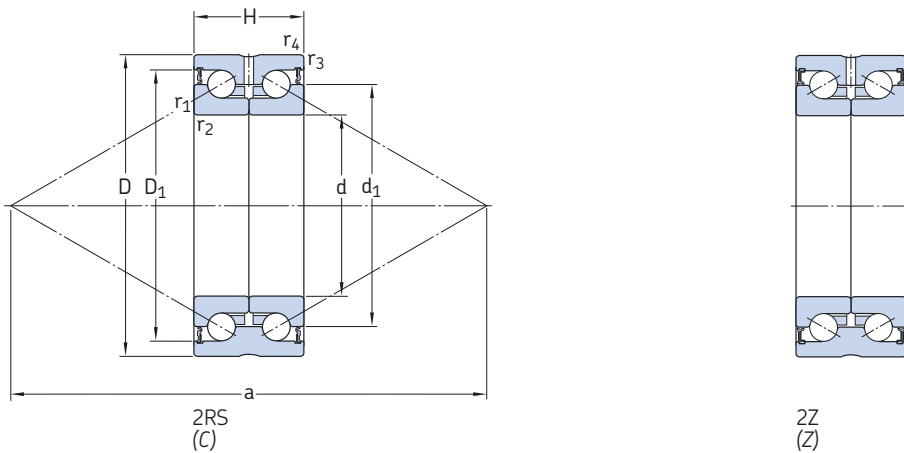

Principal dimensions			Basic load ratings		Fatigue load limit	Attainable speed	Mass	Designations SKF	SNFA
d	D	H	C	C <sub>0</sub>	P <sub>u</sub>				
mm			kN		kN	r/min	kg	–	
<b>8</b>	32	20	12,5	16,3	0,6	5 300	0,09	<b>BEAS 008032-2RS</b>	<b>BEAS 8/32/C 7P60</b>
	32	20	12,5	16,3	0,6	8 800	0,09	<b>BEAS 008032-2Z</b>	<b>BEAS 8/32/Z 7P60</b>
<b>12</b>	42	25	16,8	24,5	0,915	4 000	0,2	<b>BEAS 012042-2RS</b>	<b>BEAS 12/42/C 7P60</b>
	42	25	16,8	24,5	0,915	6 700	0,2	<b>BEAS 012042-2Z</b>	<b>BEAS 12/42/Z 7P60</b>
<b>15</b>	45	25	18	28	1,04	3 900	0,21	<b>BEAS 015045-2RS</b>	<b>BEAS 15/45/C 7P60</b>
	45	25	18	28	1,04	6 500	0,21	<b>BEAS 015045-2Z</b>	<b>BEAS 125/45/Z 7P60</b>
<b>17</b>	47	25	19	31	1,16	3 800	0,22	<b>BEAS 017047-2RS</b>	<b>BEAS 17/47/C 7P60</b>
	47	25	19	31	1,16	6 300	0,22	<b>BEAS 017047-2Z</b>	<b>BEAS 17/47/Z 7P60</b>
<b>20</b>	52	28	26	46,5	1,73	3 400	0,31	<b>BEAS 020052-2RS</b>	<b>BEAS 20/52/C 7P60</b>
	52	28	26	46,5	1,73	6 000	0,31	<b>BEAS 020052-2Z/PE</b>	<b>BEAS 20/52/Z SQP60</b>
	52	28	26	46,5	1,73	6 000	0,31	<b>BEAS 020052-2Z</b>	<b>BEAS 20/52/Z 7P60</b>
<b>25</b>	57	28	27,6	55	2,04	3 400	0,34	<b>BEAS 025057-2RS</b>	<b>BEAS 25/57/C 7P60</b>
	57	28	27,6	55	2,04	5 600	0,34	<b>BEAS 025057-2Z</b>	<b>BEAS 25/57/Z 7P60</b>
<b>30</b>	62	28	29	64	2,36	3 200	0,39	<b>BEAS 030062-2RS</b>	<b>BEAS 30/62/C 7P60</b>
	62	28	29	64	2,36	5 300	0,39	<b>BEAS 030062-2Z</b>	<b>BEAS 30/62/Z 7P60</b>

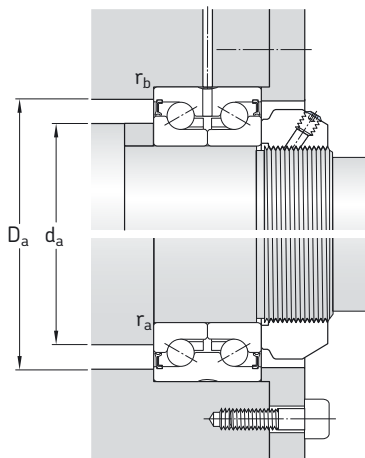

Dimensions						Abutment and fillet dimensions			
d	d <sub>1</sub>	D <sub>1</sub>	r <sub>1,2</sub>	r <sub>3,4</sub> min	a	d <sub>a</sub> min	D <sub>a</sub> max	r <sub>a</sub> max	r <sub>b</sub> max
mm						mm			
8	19	26,5	0,3	0,6	43	12	26	0,3	0,6
	19	26,5	0,3	0,6	43	12	26	0,3	0,6
12	25	33,5	0,3	0,6	56	16	35	0,3	0,6
	25	33,5	0,3	0,6	56	16	35	0,3	0,6
15	28	36	0,3	0,6	61	20	35	0,3	0,6
	28	36	0,3	0,6	61	20	35	0,3	0,6
17	30	38	0,3	0,6	65	23	40	0,3	0,6
	30	38	0,3	0,6	65	23	40	0,3	0,6
20	34,5	44	0,3	0,6	74	26	45	0,3	0,6
	34,5	44	0,3	0,6	74	26	45	0,3	0,6
	34,5	44	0,3	0,6	74	26	45	0,3	0,6
25	40,5	49	0,3	0,6	84	32	50	0,3	0,6
	40,5	49	0,3	0,6	84	32	50	0,3	0,6
30	45,5	54	0,3	0,6	93	40	54	0,3	0,6
	45,5	54	0,3	0,6	93	40	54	0,3	0,6

# Double direction angular contact thrust ball bearings for bolt mounting

d 12 – 60 mm

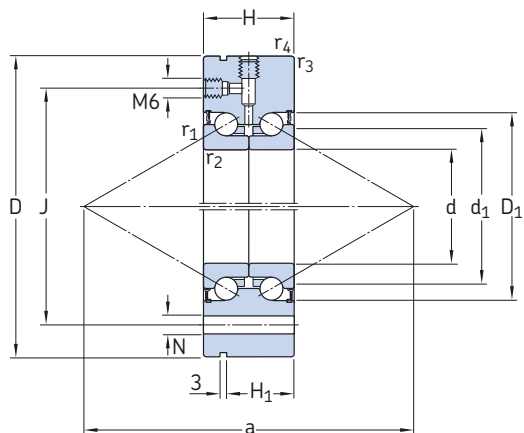

Design for  
d = 60 mm



PE  
(SQ)

## Principal dimensions

Basic load ratings  
dynamic static

Fatigue  
load limit

Attainable  
speed

Mass

Designations  
SKF

SNFA

d	D	H	C	C <sub>0</sub>	P <sub>u</sub>				
mm			kN		kN	r/min	kg	–	
12	55	25	16,8	24,5	0,915	4 000	0,37	BEAM 012055-2RS	BEAM 12/55/C 7P60
	55	25	16,8	24,5	0,915	6 700	0,37	BEAM 012055-2Z	BEAM 12/55/Z 7P60
17	62	25	19	31	1,16	3 800	0,45	BEAM 017062-2RS	BEAM 17/62/C 7P60
	62	25	19	31	1,16	3 800	0,45	BEAM 017062-2RS/PE	BEAM 17/62/C SQP60
	62	25	19	31	1,16	6 300	0,45	BEAM 017062-2Z	BEAM 17/62/Z 7P60
	62	25	19	31	1,16	6 300	0,45	BEAM 017062-2Z/PE	BEAM 17/62/Z SQP60
20	68	28	26	46,5	1,73	3 400	0,61	BEAM 020068-2RS	BEAM 20/68/C 7P60
	68	28	26	46,5	1,73	3 400	0,61	BEAM 020068-2RS/PE	BEAM 20/68/C SQP60
	68	28	26	46,5	1,73	6 000	0,61	BEAM 020068-2Z	BEAM 20/68/Z 7P60
	68	28	26	46,5	1,73	6 000	0,61	BEAM 020068-2Z/PE	BEAM 20/68/Z SQP60
25	75	28	27,6	55	2,04	3 400	0,72	BEAM 025075-2RS	BEAM 25/75/C 7P60
	75	28	27,6	55	2,04	3 400	0,72	BEAM 025075-2RS/PE	BEAM 25/75/C SQP60
	75	28	27,6	55	2,04	5 600	0,72	BEAM 025075-2Z	BEAM 25/75/Z 7P60
	75	28	27,6	55	2,04	5 600	0,72	BEAM 025075-2Z/PE	BEAM 25/75/Z SQP60
30	80	28	29,1	64	2,36	2 600	0,78	BEAM 030080-2RS	BEAM 30/80/C 7P60
	80	28	29,1	64	2,36	2 600	0,78	BEAM 030080-2RS/PE	BEAM 30/80/C SQP60
	80	28	29,1	64	2,36	4 500	0,78	BEAM 030080-2Z	BEAM 30/80/Z 7P60
	100	38	60	108	4	2 600	1,65	BEAM 030100-2RS	BEAM 30/100/C 7P60
100	38	60	108	4	4 300	1,65	BEAM 030100-2Z	BEAM 30/100/Z 7P60	
35	90	34	41	88	3,25	2 400	1,15	BEAM 035090-2RS	BEAM 35/90/C 7P60
	90	34	41	88	3,25	4 000	1,15	BEAM 035090-2Z	BEAM 35/90/Z 7P60
40	100	34	43,6	102	3,75	2 200	1,45	BEAM 040100-2RS	BEAM 40/100/C 7P60
	100	34	43,6	102	3,75	3 800	1,45	BEAM 040100-2Z	BEAM 40/100/Z 7P60
	115	46	71,5	150	5,5	1 800	2,2	BEAM 040115-2RS	BEAM 40/115/C 7P60
	115	46	71,5	150	5,5	3 000	2,2	BEAM 040115-2Z	BEAM 40/115/Z 7P60
50	115	34	46,8	127	4,65	2 000	1,85	BEAM 050115-2RS	BEAM 50/115/C 7P60
	115	34	46,8	127	4,65	3 600	1,85	BEAM 050115-2Z	BEAM 50/115/Z 7P60
	140	54	112	250	9,3	1 700	4,7	BEAM 050140-2RS	BEAM 50/140/C 7P60
	140	54	112	250	9,3	2 800	4,7	BEAM 050140-2Z	BEAM 50/140/Z 7P60
60	145	45	85,2	216	8	1 600	4,3	BEAM 060145-2RS	BEAM 60/145/C 7P60
	145	45	85,2	216	8	2 600	4,3	BEAM 060145-2Z	BEAM 60/145/Z 7P60

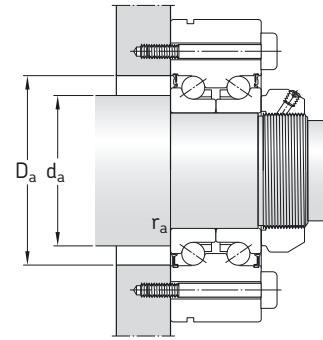
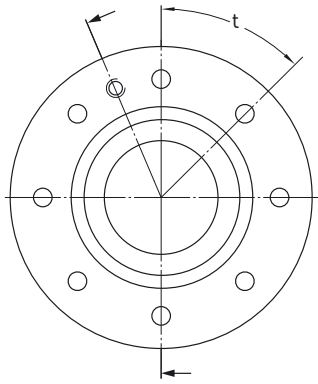

Dimensions							Abutment and fillet dimensions			Holes for attachment bolts to DIN 912			
d	d <sub>1</sub>	D <sub>1</sub>	H <sub>1</sub>	r <sub>1,2</sub>	r <sub>3,4</sub>	a	d <sub>a</sub>	D <sub>a</sub>	r <sub>a</sub>	Size	J	N	t
mm	~	~	~	min	min		max	max	max	–	mm		No. of holes × degree
12	25	33,5	17	0,3	0,6	56	16	33	0,6	M6	42	6,8	3×120°
	25	33,5	17	0,3	0,6	56	16	33	0,6	M6	42	6,8	3×120°
17	30	38	17	0,3	0,6	65	23	38	0,6	M6	48	6,8	3×120°
	30	38	17	0,3	0,6	65	23	38	0,6	M6	48	6,8	3×120°
	30	38	17	0,3	0,6	65	23	38	0,6	M6	48	6,8	3×120°
	30	38	17	0,3	0,6	65	23	38	0,6	M6	48	6,8	3×120°
20	34,5	44	19	0,3	0,6	74	25	44	0,6	M6	53	6,8	4×90°
	34,5	44	19	0,3	0,6	74	25	44	0,6	M6	53	6,8	4×90°
	34,5	44	19	0,3	0,6	74	25	44	0,6	M6	53	6,8	4×90°
	34,5	44	19	0,3	0,6	74	25	44	0,6	M6	53	6,8	4×90°
25	40,5	49	19	0,3	0,8	84	32	49	0,6	M6	58	6,8	4×90°
	40,5	49	19	0,3	0,8	84	32	49	0,6	M6	58	6,8	4×90°
	40,5	49	19	0,3	0,8	84	32	49	0,6	M6	58	6,8	4×90°
	40,5	49	19	0,3	0,8	84	32	49	0,6	M6	58	6,8	4×90°
30	45,5	54	19	0,3	0,6	93	40	54	0,6	M6	63	6,8	6×60°
	45,5	54	19	0,3	0,6	93	40	54	0,6	M6	63	6,8	6×60°
	45,5	54	19	0,3	0,6	93	40	54	0,6	M6	63	6,8	6×60°
	51	65	30	0,3	0,6	106	47	65	0,6	M8	80	8,8	8×45°
	51	65	30	0,3	0,6	106	47	65	0,6	M8	80	8,8	8×45°
35	52	63	25	0,3	0,6	107	45	63	0,6	M8	75	8,8	4×90°
	52	63	25	0,3	0,6	107	45	63	0,6	M8	75	8,8	4×90°
40	58	68	25	0,3	0,6	117	50	68	0,6	M8	80	8,8	4×90°
	58	68	25	0,3	0,6	117	50	68	0,6	M8	80	8,8	4×90°
	65	80	36	0,6	0,6	134	56	80	0,6	M8	94	8,8	12×30°
	65	80	36	0,6	0,6	134	56	80	0,6	M8	94	8,8	12×30°
50	72	82	25	0,3	0,6	141	63	82	0,6	M8	94	8,8	6×60°
	72	82	25	0,3	0,6	141	63	82	0,6	M8	94	8,8	6×60°
	80	98	45	0,6	0,6	166	63	98	0,6	M10	113	11	12×30°
	80	98	45	0,6	0,6	166	63	98	0,6	M10	113	11	12×30°
60	85	100	35	0,6	0,6	168	82	100	0,6	M8	120	8,8	8×45°
	85	100	35	0,6	0,6	168	82	100	0,6	M8	120	8,8	8×45°

Cartridge units with a flanged housing  
d 20 – 60 mm

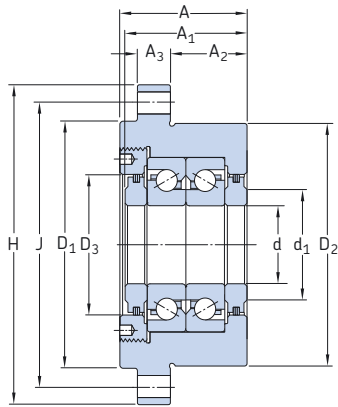

FBSA 2 .. /DB  
(BSDU 2 .. DD)

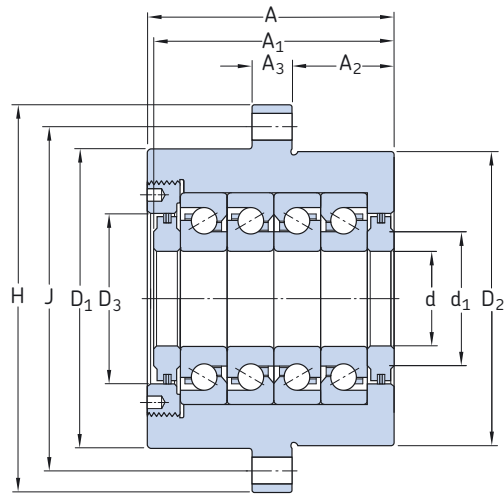

FBSA 2 .. /QBC  
(BSQU 2 .. TDT)

Dimensions															Designations	
d	A	A <sub>1</sub>	A <sub>2</sub>	A <sub>3</sub>	C	d <sub>1</sub>	D <sub>1</sub>	D <sub>2</sub>	D <sub>3</sub>	H	J	J <sub>1</sub>	N	G	SKF	SNFA
mm																
20	47	44,26	32	13	-	26	64	60	36	90	76	32	6,6	-	FBSA 204/DB	BSDU 220 DD
	47	43,24	32	13	-	26	64	60	36	90	76	32	6,6	-	FBSA 204/DF	BSDU 220 FF
	77	74,26	32	13	-	26	64	60	36	90	76	32	6,6	-	FBSA 204/QBC	BSQU 220 TDT
	77	72,74	32	13	-	26	64	60	36	90	76	32	6,6	-	FBSA 204/QFC	BSQU 220 TFT
25	52	50,26	32	15	-	34	88	80	36	120	102	44	9,2	-	FBSA 205/DB	BSDU 225 DD
	52	49,24	32	15	-	34	88	80	36	120	102	44	9,2	-	FBSA 205/DF	BSDU 225 FF
	82	80,26	32	15	-	34	88	80	40	120	102	44	9,2	-	FBSA 205/QBC	BSQU 225 TDT
	82	78,74	32	15	-	34	88	80	40	120	102	44	9,2	-	FBSA 205/QFC	BSQU 225 TFT
30	52	50,26	32	15	-	41	88	80	50	120	102	44	9,2	-	FBSA 206/DB	BSDU 230 DD
	52	49,24	32	15	-	41	88	80	50	120	102	44	9,2	-	FBSA 206/DF	BSDU 230 FF
	84	82,26	32	15	-	41	88	80	50	120	102	44	9,2	-	FBSA 206/QBC	BSQU 230 TDT
	84	80,74	32	15	-	41	88	80	50	120	102	44	9,2	-	FBSA 206/QFC	BSQU 230 TFT
	86	86,26	3,5	15	35	41	88	88	50	120	102	45	9,2	M8x1,25	FBSA 206 A/QBC	BSQU 230/1 TDT
	86	86,26	3,5	15	35	41	88	88	50	120	102	45	9,2	M8x1,25	FBSA 206 A/QFC	BSQU 230/1 TFT
35	52	50,26	32	15	-	46	98	90	60	130	113	49	9,2	-	FBSA 207/DB	BSDU 235 DD
	52	49,24	32	15	-	46	98	90	60	130	113	49	9,2	-	FBSA 207/DF	BSDU 235 FF
	86	84,26	32	15	-	46	98	90	60	130	113	49	9,2	-	FBSA 207/QBC	BSQU 235 TDT
	86	82,74	32	15	-	46	98	90	60	130	113	49	9,2	-	FBSA 207/QFC	BSQU 235 TFT
40	66	64,26	43,5	17	-	55	128	124	66	165	146	64	11,4	-	FBSA 208/DB	BSDU 240 DD
	66	63,24	43,5	17	-	55	128	124	66	165	146	64	11,4	-	FBSA 208/DF	BSDU 240 FF
	106	104,26	43,5	17	-	55	128	124	66	165	146	64	11,4	-	FBSA 208/QBC	BSQU 240 TDT
	106	102,74	43,5	17	-	55	128	124	66	165	146	64	11,4	-	FBSA 208/QFC	BSQU 240 TFT
	106	106,26	4	24	35	55	128	128	66	165	146	65,5	11,4	M10x1,5	FBSA 208 A/QBC	BSQU 240/1 TDT
	106	106,26	4	24	35	55	128	128	66	165	146	65,5	11,4	M10x1,5	FBSA 208 A/QFC	BSQU 240/1 TFT
45	66	64,26	43,5	17	-	66	128	124	76	165	146	64	11,4	-	FBSA 209/DB	BSDU 245 DD
	66	63,24	43,5	17	-	66	128	124	76	165	146	64	11,4	-	FBSA 209/DF	BSDU 245 FF
	106	104,26	43,5	17	-	66	128	124	76	165	146	64	11,4	-	FBSA 209/QBC	BSQU 245 TDT
	106	102,74	43,5	17	-	66	128	124	76	165	146	64	11,4	-	FBSA 209/QFC	BSQU 245 TFT
50	66	64,26	43,5	17	-	66	128	124	76	165	146	64	11,4	-	FBSA 210/DB	BSDU 250 DD
	66	63,24	43,5	17	-	66	128	124	76	165	146	64	11,4	-	FBSA 210/DF	BSDU 250 FF
	106	104,26	43,5	17	-	66	128	124	76	165	146	64	11,4	-	FBSA 210/QBC	BSQU 250 TDT
	106	102,74	43,5	17	-	66	128	124	76	165	146	64	11,4	-	FBSA 210/QFC	BSQU 250 TFT
	106	106,26	4	24	35	66	128	128	76	165	146	65,5	11,4	M10x1,5	FBSA 210 A/QBC	BSQU 250/1 TDT
	106	106,26	4	24	35	66	128	128	76	165	146	65,5	11,4	M10x1,5	FBSA 210 A/QFC	BSQU 250/1 TFT
60	114	114,26	20,5	25	40	80	145	145	92	185	165	74,5	11,4	M10x1,5	FBSA 212 A/QBC	BSQU 260/1 TDT
	114	114,26	20,5	25	40	80	145	145	92	185	165	74,5	11,4	M10x1,5	FBSA 212 A/QFC	BSQU 260/1 TFT

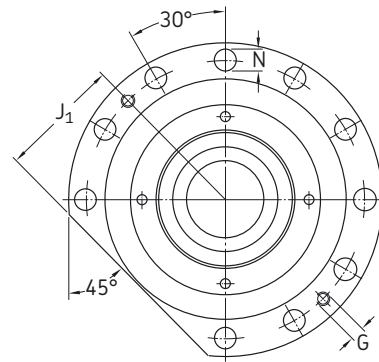
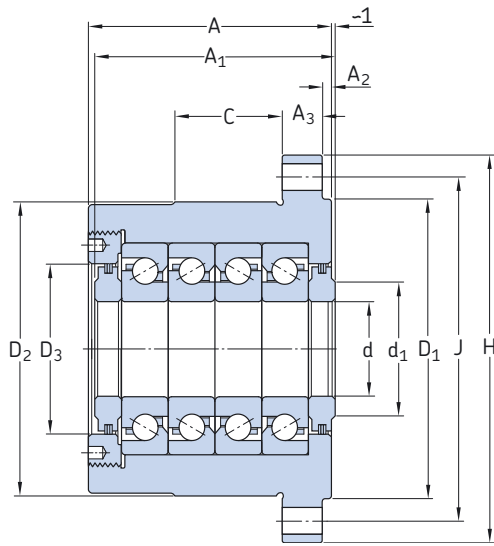

FBSA 2 .. A/QBC  
(BSQU 2 .. /1 TDT)

Mass	Basic load ratings		Fatigue load limit $P_u$	Axial stiffness		Frictional moments		Attainable speeds	
	dynamic C	static $C_0$		Preload class A	B	Preload class A	B	Preload class A	B
kg	kN			N/ $\mu$ m		Nm		r/min	
1,1	22	49	1,8	680	860	0,05	0,091	7 600	3 800
1,1	22	49	1,8	680	860	0,05	0,091	7 600	3 800
1,7	35,86	98	3,6	1 360	1 720	0,1	0,182	4 750	2 375
1,7	35,86	98	3,6	1 360	1 720	0,1	0,182	4 750	2 375
2,3	22,4	52	1,93	725	925	0,069	0,12	7 200	3 600
2,3	22,4	52	1,93	725	925	0,069	0,12	7 200	3 600
3,5	36,512	104	3,86	1 450	1 850	0,138	0,24	4 500	2 250
3,5	36,512	104	3,86	1 450	1 850	0,138	0,24	4 500	2 250
2,5	28,5	71	2,65	870	1 110	0,12	0,21	6 400	3 200
2,5	28,5	71	2,65	870	1 110	0,12	0,21	6 400	3 200
3,5	46,455	142	5,3	1 740	2 220	0,24	0,42	4 000	2 000
3,5	46,455	142	5,3	1 740	2 220	0,24	0,42	4 000	2 000
3,7	46,455	142	5,3	1 740	2 220	0,24	0,42	4 000	2 000
3,7	46,455	142	5,3	1 740	2 220	0,24	0,42	4 000	2 000
3,2	36,5	98	3,65	1 080	1 370	0,18	0,32	5 600	2 800
3,2	36,5	98	3,65	1 080	1 370	0,18	0,32	5 600	2 800
4,6	59,495	196	7,3	2 160	2 740	0,36	0,64	3 500	1 750
4,6	59,495	196	7,3	2 160	2 740	0,36	0,64	3 500	1 750
6,1	42,5	112	4,15	1 130	1 440	0,212	0,46	5 040	2 520
6,1	42,5	112	4,15	1 130	1 440	0,212	0,46	5 040	2 520
9,7	69,275	224	8,3	2 260	2 880	0,424	0,92	3 150	1 575
9,7	69,275	224	8,3	2 260	2 880	0,424	0,92	3 150	1 575
10	69,275	224	8,3	2 260	2 880	0,424	0,92	3 150	1 575
10	69,275	224	8,3	2 260	2 880	0,424	0,92	3 150	1 575
5,9	45	134	4,9	1 290	1 640	0,23	0,52	5 040	2 520
5,9	45	134	4,9	1 290	1 640	0,23	0,52	5 040	2 520
9,4	73,35	268	9,8	2 580	3 280	0,46	1,04	3 150	1 575
9,4	73,35	268	9,8	2 580	3 280	0,46	1,04	3 150	1 575
5,7	46,5	146	5,4	1 410	1 800	0,31	0,68	4 800	2 400
5,7	46,5	146	5,4	1 410	1 800	0,31	0,68	4 800	2 400
9,1	75,795	292	10,8	2 820	3 600	0,62	1,36	3 000	1 500
9,1	75,795	292	10,8	2 820	3 600	0,62	1,36	3 000	1 500
9,3	75,795	292	10,8	2 820	3 600	0,62	1,36	3 000	1 500
9,3	75,795	292	10,8	2 820	3 600	0,62	1,36	3 000	1 500
12,3	113,285	432	16	3 280	4 160	1,08	2,1	2 500	1 250
12,3	113,285	432	16	3 280	4 160	1,08	2,1	2 500	1 250

# SKF – the knowledge engineering company

From the company that invented the self-aligning ball bearing more than 100 years ago, SKF has evolved into a knowledge engineering company that is able to draw on five technology platforms to create unique solutions for its customers. These platforms include bearings, bearing units and seals, of course, but extend to other areas including: lubricants and lubrication systems, critical for long bearing life in many applications; mechatronics that combine mechanical and electronics knowledge into systems for more effective linear motion and sensorized solutions; and a full range of services, from design and logistics support to condition monitoring and reliability systems.

Though the scope has broadened, SKF continues to maintain the world's leadership in the design, manufacture and marketing of rolling bearings, as well as complementary products such as radial seals. SKF also holds an increasingly important position in the market for linear motion products, high-precision aerospace bearings, machine tool spindles and plant maintenance services.

The SKF Group is globally certified to ISO 14001, the international standard for environmental management, as well as OHSAS 18001, the health and safety management standard. Individual divisions have been approved for quality certification in accordance with ISO 9001 and other customer specific requirements.

With over 120 manufacturing sites worldwide and sales companies in 70 countries, SKF is a truly international corporation. In addition, our distributors and dealers in some 15 000 locations around the world, an e-business marketplace and a global distribution system put SKF close to customers for the supply of both products and services. In essence, SKF solutions are available wherever and whenever customers need them. Overall, the SKF brand and the corporation are stronger than ever. As the knowledge engineering company, we stand ready to serve you with world-class product competencies, intellectual resources, and the vision to help you succeed.



© Airbus – photo: e\*em company, H. Goussé

### ***Evolving by-wire technology***

*SKF has a unique expertise in the fast-growing by-wire technology, from fly-by-wire, to drive-by-wire, to work-by-wire. SKF pioneered practical fly-by-wire technology and is a close working partner with all aerospace industry leaders. As an example, virtually all aircraft of the Airbus design use SKF by-wire systems for cockpit flight control.*

*SKF is also a leader in automotive by-wire technology, and has partnered with automotive engineers to develop two concept cars, which employ SKF mechatronics for steering and braking. Further by-wire development has led SKF to produce an all-electric forklift truck, which uses mechatronics rather than hydraulics for all controls.*

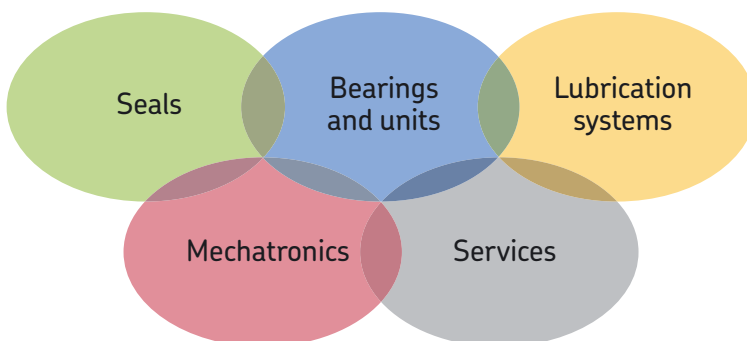





#### **Harnessing wind power**

The growing industry of wind-generated electric power provides a source of clean, green electricity. SKF is working closely with global industry leaders to develop efficient and trouble-free turbines, providing a wide range of large, highly specialized bearings and condition monitoring systems to extend equipment life of wind farms located in even the most remote and inhospitable environments.



#### **Working in extreme environments**

In frigid winters, especially in northern countries, extreme sub-zero temperatures can cause bearings in railway axleboxes to seize due to lubrication starvation. SKF created a new family of synthetic lubricants formulated to retain their lubrication viscosity even at these extreme temperatures. SKF knowledge enables manufacturers and end user customers to overcome the performance issues resulting from extreme temperatures, whether hot or cold. For example, SKF products are at work in diverse environments such as baking ovens and instant freezing in food processing plants.



#### **Developing a cleaner cleaner**

The electric motor and its bearings are the heart of many household appliances. SKF works closely with appliance manufacturers to improve their products' performance, cut costs, reduce weight, and reduce energy consumption. A recent example of this cooperation is a new generation of vacuum cleaners with substantially more suction. SKF knowledge in the area of small bearing technology is also applied to manufacturers of power tools and office equipment.



#### **Maintaining a 350 km/h R&D lab**

In addition to SKF's renowned research and development facilities in Europe and the United States, Formula One car racing provides a unique environment for SKF to push the limits of bearing technology. For over 60 years, SKF products, engineering and knowledge have helped make Scuderia Ferrari a formidable force in F1 racing. (The average racing Ferrari utilizes around 150 SKF components.) Lessons learned here are applied to the products we provide to automakers and the aftermarket worldwide.



#### **Delivering Asset Efficiency Optimization**

Through SKF Reliability Systems, SKF provides a comprehensive range of asset efficiency products and services, from condition monitoring hardware and software to maintenance strategies, engineering assistance and machine reliability programmes. To optimize efficiency and boost productivity, some industrial facilities opt for an Integrated Maintenance Solution, in which SKF delivers all services under one fixed-fee, performance-based contract.



#### **Planning for sustainable growth**

By their very nature, bearings make a positive contribution to the natural environment, enabling machinery to operate more efficiently, consume less power, and require less lubrication. By raising the performance bar for our own products, SKF is enabling a new generation of high-efficiency products and equipment. With an eye to the future and the world we will leave to our children, the SKF Group policy on environment, health and safety, as well as the manufacturing techniques, are planned and implemented to help protect and preserve the earth's limited natural resources. We remain committed to sustainable, environmentally responsible growth.

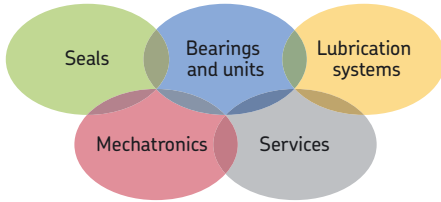

### The Power of Knowledge Engineering

Drawing on five areas of competence and application-specific expertise amassed over more than 100 years, SKF brings innovative solutions to OEMs and production facilities in every major industry worldwide. These five competence areas include bearings and units, seals, lubrication systems, mechatronics (combining mechanics and electronics into intelligent systems), and a wide range of services, from 3-D computer modelling to advanced condition monitoring and reliability and asset management systems. A global presence provides SKF customers uniform quality standards and worldwide product availability.

© SKF is a registered trademark of the SKF Group.

© SKF Group 2012

The contents of this publication are the copyright of the publisher and may not be reproduced (even extracts) unless prior written permission is granted. Every care has been taken to ensure the accuracy of the information contained in this publication but no liability can be accepted for any loss or damage whether direct, indirect or consequential arising out of the use of the information contained herein.

PUB BU/P2 06570/2 EN · April 2012

This publication supersedes chapter 5 in publication 6002 EN.

